

RIVETEC 

TITGEMEYER Group

RL 20A

Operating Manual



Table of contents

Guiding instructions	4
Cautions, instructions and procedural sections in the operating instructions	5
Markings on the riveting tool	6
Safety instructions	7
Basic requirements while dealing with the riveting tool	8
Noise and vibration levels of the RL 20A.....	10
Description of the riveting tool	11
Necessary tools	13
Storing the riveting tool	13
Preparing the riveting tool	14
Operating the riveting tool	17
Setting the blind rivet	18
Changing the nose piece.....	19

Maintaining the riveting tool.....	20
Bleeding the hydraulic section, refilling hydraulic oil	20
Changing the jaws	22
Adjusting the jaw case body	24
Table for torque values	25
Servicing and cleaning the riveting tool	26
Maintenance intervals	27
Trouble shooting.....	28
Disposal of the riveting tool	31
Technical data	31
Guarantee	32
List of parts	33
Declaration of conformity	36

Guiding instructions

Instruction	The legislator prescribes that the user must be well trained for using compressor-driven riveting tools. If desired, the training programme can be conducted at RIVETEC or directly at the client's place.
Technological level	This riveting tool is as per the latest technological standards. For the device to function properly, it is necessary to operate it in an expertly manner, with adherence to safety requirements.
Reading the guiding instructions	Before using the riveting tool for the first time, read the guiding instructions carefully.
Procedures	All the procedures necessary for the operation have been described in these guiding instructions. You may carry out only those procedures, which have been described here.
Obstructions	In case of obstructions, you may repair only those obstructions, which have been marked with a O (Operator).
Illustrations and position-codes	All the illustrations and position-codes in the individual diagrams take reference from the list of parts in the last pages.
Table for torque values	For sizes of screws and threads, you will find a table containing the torque values in the chapter "Maintening the riveting tool".

Cautions, instructions and procedural sections in the operating instructions

Please follow the instructions and safety informations.

In these operating instructions, some sections have been further illustrated through diagrams

Please acquaint yourself well with these diagrams and their meanings:



Caution Hazard of injury! This marking indicates a potential hazard.



Attention Material damage! This marking points at a procedure, which may cause damage to the riveting tool or the work-piece.



Note This marking indicates useful information

- This point (•) marks every paragraph, which requires you to act by yourself.



Attention Environmental hazard! This marking indicates a potential environmental hazard.



Markings on the riveting tool

This pictogram indicates that you must read the operating instructions before using the riveting tool.

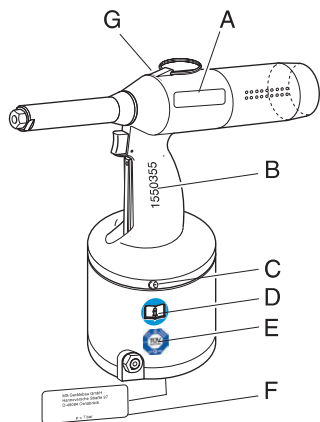

A Marking of the type

B Serial number

C CE-marking

D Instruction for reading the operating instructions

E TÜV-Mark (safety checked)

F Name of the manufacturer as well as the value of the maximum operating pressure

G Supplier

Safety instructions

Application as per the purpose

The riveting tool is meant exclusively for setting blind rivets. The riveting tool RL 20A has been designed for setting all materials of blind rivets with a shank diameter of 2.4 to 5.0 mm. This riveting tool must be used only as a hand-held device! The client is fully responsible for any modifications to the riveting tool!

Improper use

Never throw away or drop the riveting tool!

Clean and dry compressed air

Please take care that only clean and dry compressed air is let into the riveting tool. Moisture and dirt can damage the riveting tool. Use only such compressed air, which falls into class 2 of air quality as per ISO 8573-1.



Caution Hazard of injury because of explosion! Never use the riveting tool in an atmosphere prone to explosions. Ensure that the workplace is well lit and clean.
Hazard of injury due to the openly moving compressed air hose. Connect and lay the compressed air hose properly.
Hazard of injury due to tripping over! Lay the compressed air hose in such a way that nobody should trip over it.



Attention Material damage! The maximum operating pressure is 7 bar. For increasing the durability of the riveting tool, it is recommended to fit a compressed air-maintenance unit in the compressed air hose.

Basic requirements while dealing with the riveting tool



Caution Do not operate the riveting tool when it is directly pointing at any person.

Follow the prevalent guidelines for the prevention of accidents in the respective country.

Use only those fittings and hoses, which have been approved for the operating pressure.

Disconnect the compressed air supply from the riveting tool at the time of installation or maintenance.

Wear personal safety gear (safety glasses and safety helmet).



Attention Please pay attention to the information on the pack of the blind rivet.

Use the riveting tool only at operating temperatures above 5°C and 45°C.

For different diameters of the rivet shank, use the appropriate nose piece, as prescribed.

Do not throw away the riveting tool.

- Maintenance and servicing** The operator may only carry out the maintenance and repair work described in these operating instructions
- Service instructions** Maintenance and service work not described in these operating instructions may only be carried out by trained specialists following instruction by RIVETEC on the basis of the service instructions which also exist. See the address on Page 37 for more information on service instructions and training.
- **Note** The manufacturer accepts no liability for damage resulting from incorrect repairs or the use of spare parts from other sources
- At the time of leaving the workplace, do not leave the riveting tool with pressure on.
- Guarantee** A guarantee is void, if any repair work carried out on the riveting tool has lead to any damage of the riveting tool.
- Declaration of conformity** The riveting tool RL 20A has been checked and manufactured according to European guidelines. The declaration of conformity can be found on the second last page.
- GS-checked** In addition to this, the riveting tool has been checked by the TÜV Product Service GmbH, Hannover, and certified with a GS-mark.

Noise and vibration levels of the RL 20A

Noise level

The sound-emission level for workplaces is $L_{PAI} < 70 \text{ dB(A)}$ as per ISO 10843 and DIN EN 3744.

Vibration level

The effective value measured on acceleration with the handle, as per ISO/FDIS 8662-11, is $a_{hw} < 2,5 \text{ m/s}^2$.

Description of the riveting tool

The riveting tool RL 20A works according to a pneumatic-hydraulic principle.

It consists of the following operation-related components:

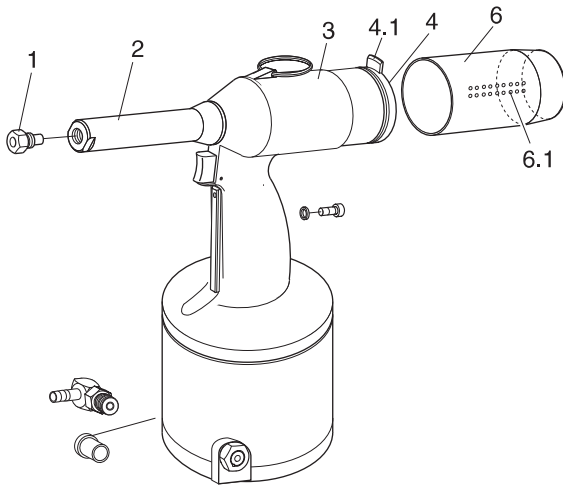

- | | | |
|---|-------------------------|---|
| 1 | Nose pieces | Nose pieces for blind rivets - (burnished black) - are screwed into the bottom of the valve housing |
| 2 | Nose cap | Conceals the jaw case body and the jaw case |
| 3 | Hydraulic housing | The pneumatic and the hydraulic units are located in the hydraulic housing |
| 4 | Safety mechanism | Prevents the spent mandrel from leaving the tool if the collector is not filled (the locking-catch nose (4.1), which is subject to spring thrust, clicks into place when the spent mandrel collector (6) is fitted on |
| 6 | Spent mandrel collector | Serves the purpose of collecting spent mandrels (with air-outlet (6.1), the direction of the escaping air can be changed). |

Description of the riveting tool

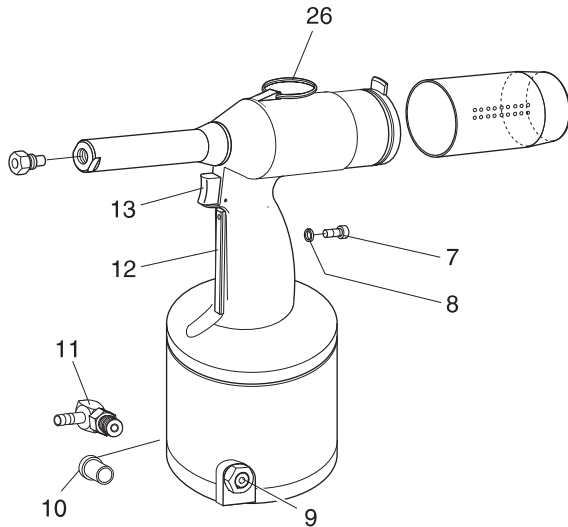

Note The socket head screw (7) and the O-ring (8) are screwed tightly into the grip. The socket head screw (7) must not be loosened, else the hydraulic oil will leak.

7	Socket headscrew	Locking for the hydraulic oil system
8	O-Ring	Sealing of the hydraulic oil system
9	Safety valve	(Brass) In case of very high pressures (approx. 8 bar or more), it opens, and lets the air out.
10	Plug	Serves the purpose of protection of the thread and also against dirt
11	Swivel-joint	Serves as the connection for compressed air hoses (operating pressure 6 bar)
12	Suction-trigger	In/out for mandrel - suction arrangement
13	Trigger	When activated, the riveting procedure starts
26	Hang-up eyelet	For hanging up on a hook whenever stationary

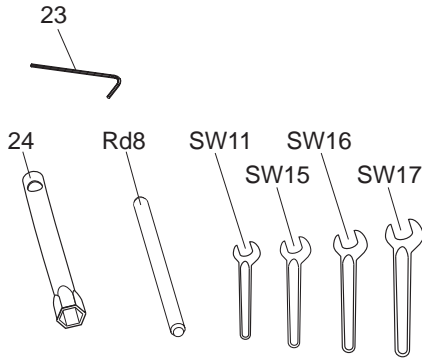

Necessary tools

You will require the following tools for all installation, servicing and maintenance work. The tools (23, 24) can be ordered.

Tools

- Internal hex key SW4 (23)
- Box wrench SW11 (24)
- Wrench¹ SW11, SW15 (2x), SW16, SW17
- Round steel¹ \varnothing 8x150 mm Rd8

¹ No delivery possibility

Storing the riveting tool

Until first use

If you do not use the riveting tool immediately, store it inside the original packing, dry and dust-free.

Long term storage after usage

Clean the riveting tool (see “Servicing and cleaning riveting tool”). Turn off the spent mandrel collector (6), unscrew the swivel joint (11), and close the opening with a plug (10). As far as possible, store all parts in their original packing.

After long-term storage

After long-term storage (about 3 years), change the hydraulic oil before re-use.

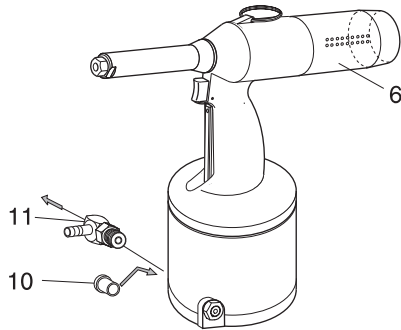

Preparing the riveting tool

Package insert

The components ordered by you are marked as per the checklist found inside the packing.



Note Please check the contents of the packing, for completeness of the checklist

In every case, please carry out a visual check of the riveting tool before starting any work:

- for external damages,
- for oil leakage from the riveting tool.

- Remove the plug (10) from the connection port, and store in the original packing.



Note The swivel joint (11) and the safety valve (9) can be alternatively fitted on both the sides of the hydraulic housing. The diagram below shows the arrangement for a right-hander.



Note In case of all screw-fittings, observe the table for torque values in the chapter “Riveting tool maintenance”

- Screw on the swivel joint (11) and tighten using the wrench SW17 (see “Table for torque values”).

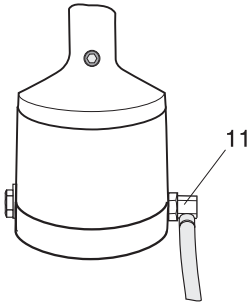
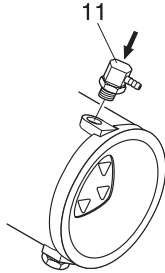
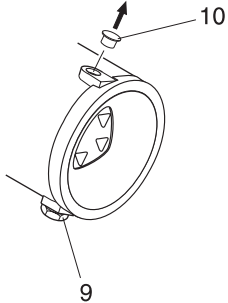

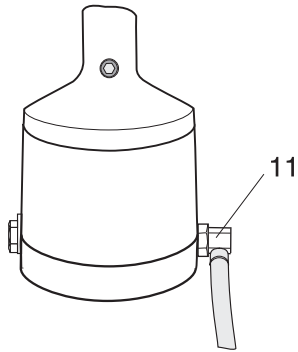

Note Depending on the type of compressed air supply, it may be necessary to connect a fitting different from the one provided, to the riveting tool. For this, you need to have a fitting having a 1/4" Withworth pipe thread as per ISO 228.



Attention Material damage by compressed air!
As per norm ISO 8573-1, class 2, compressed air must be dry and clean. We recommend that you fit a compressed air-maintenance unit to the riveting tool.

- Compressed air hose should be connected to the swivel joint (11), as prescribed.



Note The operating pressure must be between a minimum of 5 and a maximum of 7 bar!

Preparing the riveting tool

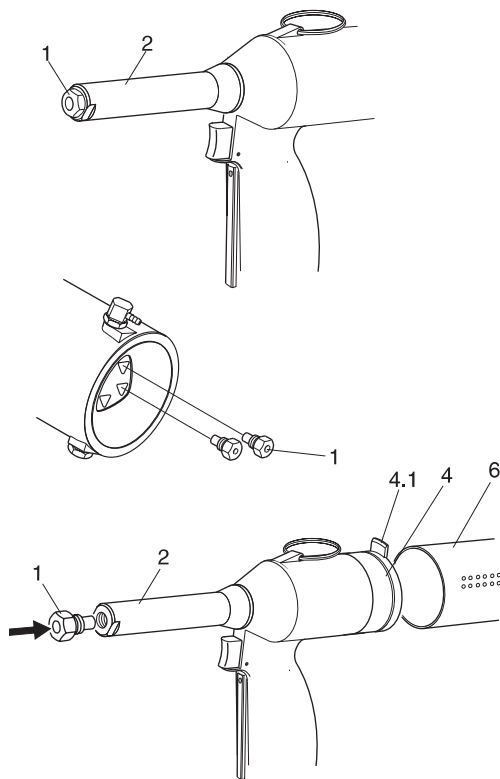

Note You may use nose pieces for rivet shank diameter of 2.4 to 5.0 mm



Note Before you start the operation procedure, check whether the appropriate nose piece (1) has been fitted. If not, then the same should be replaced with the appropriate nose piece.

- Unscrew the right nose piece (1) from the locating hole on the underside of the riveting tool, using a box wrench SW11 (24).
- Unscrew the nose piece (1) from the nose cap (2), and screw into the locating hole.



Note Clean the replaced nose piece (1) and screw into the locating hole on the underside of the riveting tool using the box wrench SW11 (24)

Attention Material damage due to damaged threads. It should be possible to screw on the nose piece with bare hands. Do not use force! You must overcome the spring thrust on the jaws.

- Screw the nose piece (1) carefully into the nose cap (2).
- Tighten the nose piece (1) using box wrench SW11 (24) (see “Table for torque values”).

Push open the spent mandrel collector:

- Put the spent mandrel collector (6) over the locking catch nose (4.1) of the safety mechanism (4).
- Push the spent mandrel collector onto the casing while rotating, until the locking catch nose (4.1) clicks into place.

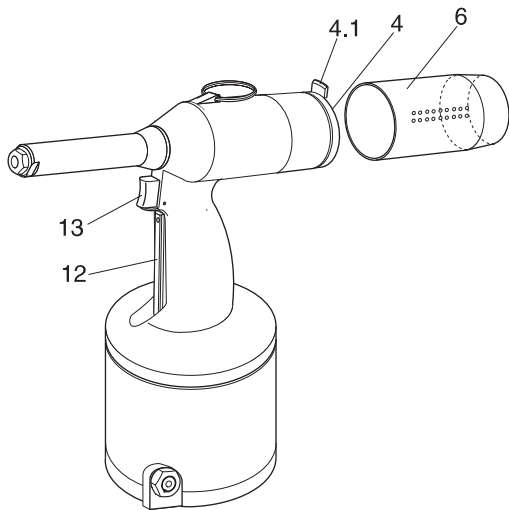

Operating the riveting tool



Caution Hazard of injury due to the rivet head coming off! Therefore, examine the riveting tool without blind rivet. Wear safety glasses.

- Connect the compressed air supply (6 bar) onto the riveting tool.
- Check the riveting tool before starting any work where you use triggers (12) and (13).



Caution Hazard of injury due to unchecked wearing out of the mandrel! Use only an undamaged spent mandrel collector, and ensure that it has been correctly fitted (locking catch nose (4.1) of the safety mechanism (4) properly clicked into place).



Attention Material damage! Always work with artificial spent mandrel collector (6)! In the absence of the spent mandrel collector, the safety mechanism (4) closes the outlet. Collected mandrels are left back in the riveting tool, where they could jam. If proper attention is not paid, then the riveting tool may break down.

Operating the riveting tool

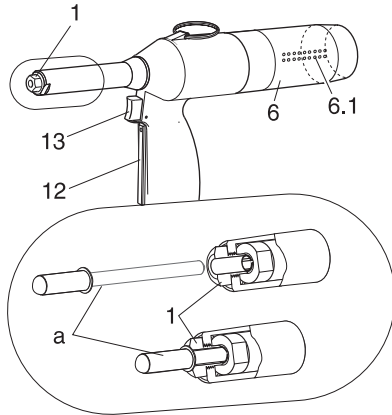
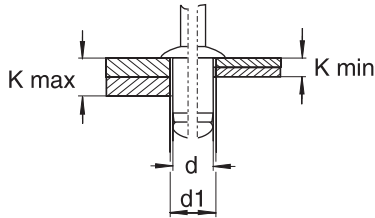
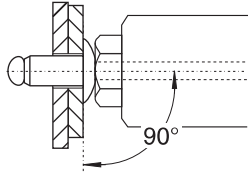

Setting the blind rivet

What you must take care of



Attention Material damage! Always set the riveting tool at the correct angle (90°) with the surface of the work-piece to be riveted. A slanted setting will lead to defective riveting.



Note For the size of the hole (d1) and of the clamping grip (K), refer to the information given by the rivet manufacturer

- Suction trigger (12) should be straightened upto the stop point and held there. Air escapes from the air outlets (6.1).
- Feed the blind rivet (a) into the nose piece (1). The blind rivet is sucked and held in the nose piece.
- Hold trigger (12), insert the blind rivet (a) into the already prepared hole, and press firmly.
- Straighten the trigger (13) upto the stop point, and hold it there. The rivet is set and the mandrel breaks off at a pre-determined break point.
- Release trigger (13). After releasing the trigger, the spent mandrel is automatically sucked into the spent mandrel collector (6).

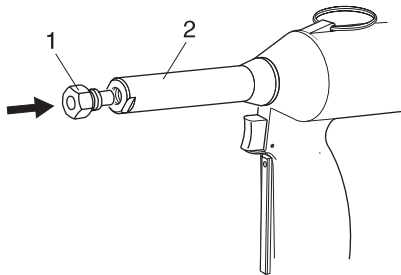
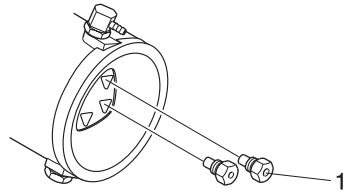
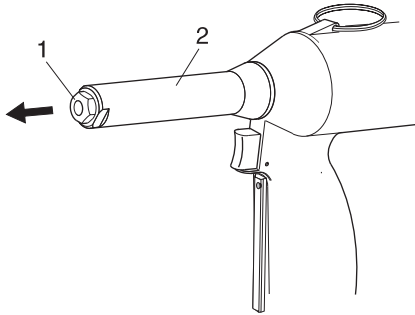

Changing the nose piece

You can adapt the riveting tool for use with blind rivets of various materials and sizes (rivet shank diameter between 2.4 and 5.0 mm), wherein you are only required to change the nose piece.



Note For a tightly fitted nose piece (1), clamp the riveting tool into a vice if required, and loosen the nose piece. If you clamp the riveting tool into a vice, then insert a soft material in-between (Alu/ wood).

- Unscrew the appropriate nose piece (1) from the collecting hole on the underside of the riveting tool using the box wrench SW11 (24).
- Unscrew the nose piece (1) from the nose cap (2).



Note Clean the replaced nose piece (1) and screw into the collecting hole on the underside of the riveting tool using the box wrench SW11 (24)



Attention Material damage due to damaged threads. It should be possible to screw on the nose piece with bare hands. Do not use force! You must overcome the spring thrust on the jaws!

- Screw the nose piece (1) carefully into the nose cap (2).
- Tighten the nose piece (1) using the box wrench SW11 (24) (see "Table for torque values").

Maintaining the riveting tool



Caution Hazard of injury if handled in an improper manner! Servicing, maintenance and repairs of the riveting tools must be carried out professionally. On completing this work, there should not be any more hazard to the operator, if used as per the regulations. The operator may only carry out the operations mentioned here.

Bleeding the hydraulic section, refilling hydraulic oil

It is necessary to bleed the hydraulic system or to refill the hydraulic oil when:

- oil is leaking from defective O-rings,
- after an oil-change at the time of an overhaul (either after a maximum of 3 years, or after 2000 working hours).

- Detach the compressed air connection.

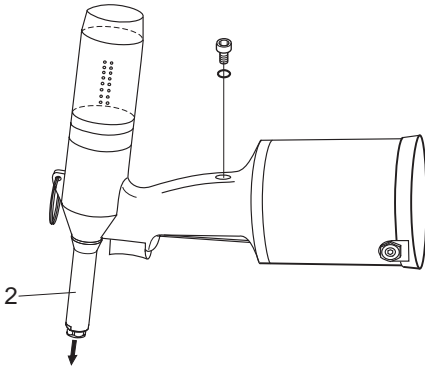

Note Unscrew nose cap (2), so that there is no more pressure on the hydraulic cylinder, else it would not be possible to fill in adequate oil



Note If you clamp the riveting tool into a vice, then insert a soft material in-between (Alu/ wood)

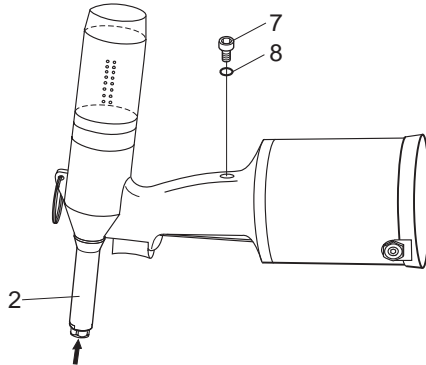
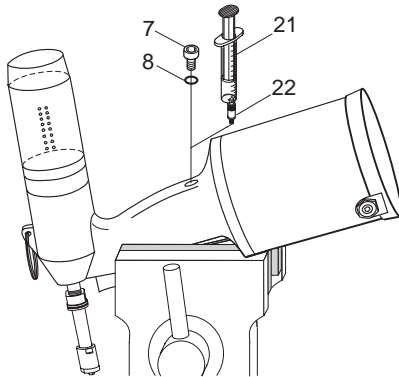

- Bend the riveting tool carefully towards the front at an angle, and fix e.g. inside a vice (like illustrated in the diagram).

This position is critical, where the trapped air can escape when necessary (bleeding the hydraulic section).



Attention Environmental hazard! Always use a large bowl for collecting oil. Please observe all the environmental regulations prevalent in the respective area.



Attention Material damage! Do not let the O-ring (8) be damaged. If the O-ring gets damaged, then replace immediately.

- Unscrew the socket head screw (7) in the hydraulic housing carefully, using the internal hex key SW4 (23).
- Screw the oil refill adapter screw (22) into the free opening.
- Set the filled oil gun (21).
- Using the oil gun (21), inject the hydraulic oil (e.g. DEA Astron HLP 32 or a similar grade oil) firmly.
- Withdraw the oil gun (21) and unscrew the oil refill adapter screw (22).
- Screw on the socket head screw (7) with O-ring (8) and tighten using an internal hex key SW4 (23) (see "Table for torque values").
- Rub the riveting tool dry.
- Screw on the nose piece (1).
- Loosen the fixed riveting tool.
- Reconnect the compressed air supply.
- Carry out a test run without blind rivet.

Maintaining the riveting tool

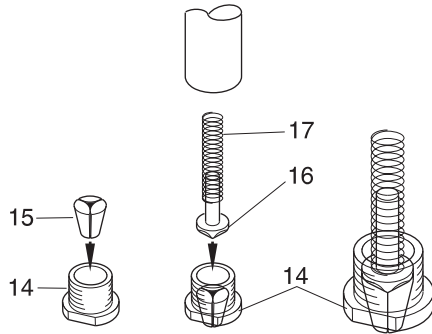
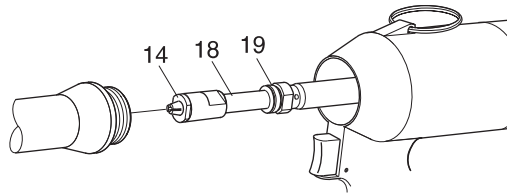
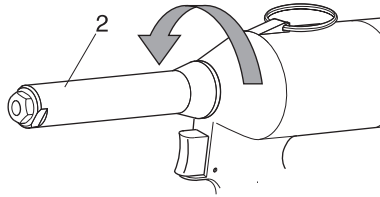

Changing the jaws

The jaws are subject to mechanical wear out, and must be replaced as soon as they start losing grip over the mandrel.

- Detach the compressed air supply.

Caution Hazard of injury by means of bruises or cuts in case of unchecked cutting stroke! Always detach compressed air supply before unscrewing the nose cap (2).

Attention Material damage! Do not let O-ring (19) get damaged. If the O-ring has been damaged, replace immediately.

- Loosen the nose cap (2) with a wrench SW16, unscrew, and separate carefully from the jaw case body (18).
- Loosen the jaw case (14) from the jaw case body (18) using a wrench SW15 (hold against the jaw case body using wrench SW15).
- Unscrew the jaw case (14) carefully by hands - the jaws (15) remain loose inside the jaws casing - and discard.
- Remove jaw pusher (16) and pressure spring (17) from the jaw case body (18) and discard.
- Remove old jaws (15) from the jaw case (14), apply little oil on the new jaws, and put to use.
- Set the jaw pusher (16) with the pressure spring (17) vertically inside the jaw case (14).

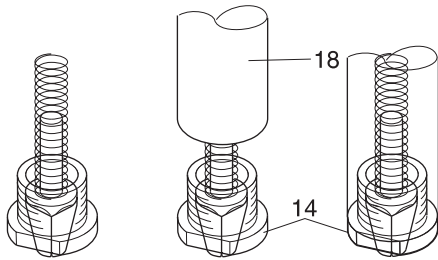

- Hold the riveting tool vertically, the jaw case body (18) shows from below.
- Insert the complete jaw case (14), along with the jaws, jaw pusher and pressure spring set in, into the jaw case body.
- Screw the jaw case (14) carefully by hands - against the thrust of the springs - into the jaw case body (18).
- Fix the jaw case body (18) using a wrench SW15 and a lock nut, and tighten the jaw case (14) using a wrench SW15 (see "Table for torque values").



Attention Material damage! If mounted correctly, then the jaws must jut out at the same level from the jaw case (14). It should be possible to press them into the jaw case (14) with the thumb.

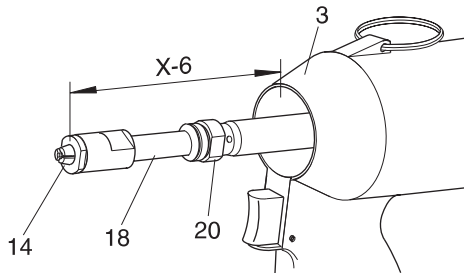

Note At the time of replacing the jaws, it may be observed that the lock nut (20) at the jaw case body (18) loosens and adjusts itself. In such a case, the gap between X - 6 needs to be readjusted (see "Adjusting the jaw case body").

Maintaining the riveting tool

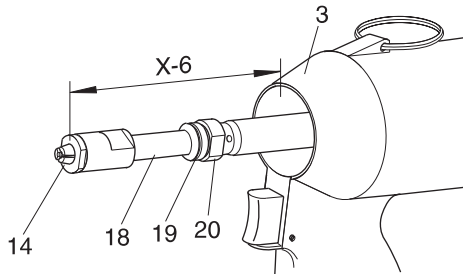
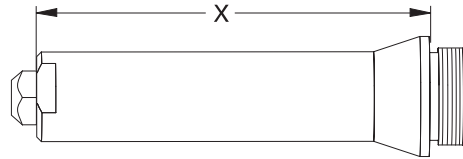
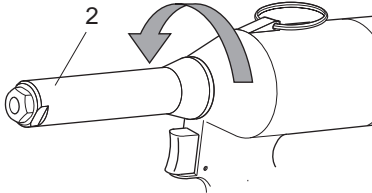

Adjusting the jaw case body

In order to enable the riveting tool to travel an adequate stroke, the gap between the jaw case (14) and hydraulic housing (3) must be adjusted correctly.

- Detach the compressed air supply.



Caution Hazard of injury by means of bruises or cuts in case of unchecked cutting stroke! Always detach compressed air supply before unscrewing the nose cap (2).



Attention Material damage! Do not let O-ring (19) get damaged. If the O-ring has been damaged, replace immediately.

- Loosen the nose cap (2) with a wrench SW16 unscrew, and separate carefully from the jaw case body (18).
- Measure the gap X at the nose cap (2) (as per diagram). For standard measurements, $X = 85$ mm.
- Measure the distance between the jaw case (14) on the facing side and the hydraulic housing (3) on the facing side; the correct distance measures up to $X - 6$ mm.
- Loosen the lock nut (20) from the jaw case body (18) using a wrench SW15, till the jaw case body (18) can rotate freely.
- Adjust the jaw case body (18) (for left or right side revolutions), till the distance of $X - 6$ mm is obtained.
- Screw the lock nut (20) against the jaw case body (18).
- Hold the jaw case body (18) in this position using a wrench SW15, and tighten the lock nut (20) using a wrench SW15.

Table for torque values

In the following table, you will find torque values, which you are required to adhere to while tightening the screws/nuts.

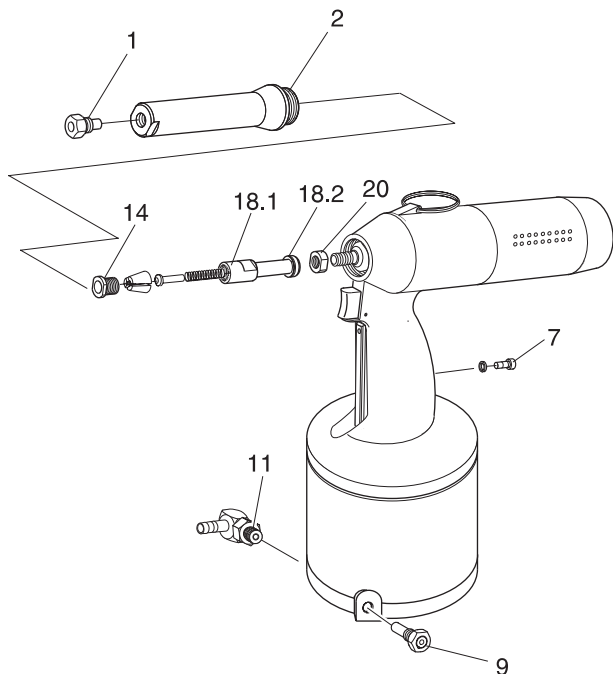

Pos.	Name	Threading	Torque value MA in Nm
1	Nose piece	Metrical M8	5
2	Nose cap	Metrical M21x1	7
7	Socket head screw	Metrical M6	4
9	Safety valve	Withworth-pipe-thread 1/4"	20
11	Swivel joint	Withworth-pipe-thread 1/4"	20
14	Jaw case	Metrical M14x1	20
18.1	Jaw case body	Metrical M14x1	20
18.2	Jaw case body	Metrical M11x1	6
20	Lock nut	Metrical M11x1	6

Servicing and cleaning riveting tool



Caution Hazard of injury if handled in an improper manner! Servicing, maintenance and repairs of the riveting tools must be carried out professionally. On completing this work, there should not be any more hazard to the operator, if used as per the regulations. The operator may only carry out the operations mentioned here.

Hazard of injury if the riveting tool falls down! The hydraulic housing must always be kept dry, clean and oil- and fat-free.



Attention Material damage due to corrosion! Do not use any highly active cleaning agents or combustible liquids for cleaning purpose!

The following routine is recommended:

The riveting tool must be cleaned and checked for mechanical defects as per the respective application type.

After the riveting tool has been cleaned and when it is to be stored for a long period, lightly grease all the external metallic components (see "Maintenance intervals").

Maintenance Intervals

Intervall	Activity	How?	Who?	Remark
Daily before use	Check for cracks	Visual check	Operator	—
Daily before use	Check nose piece for rivet diameter and wear and tear	Visual check	Operator	If required, replace nose piece
Daily before use	Check the jaws	Functional check	Operator	If required, clean and change jaws
Daily before use	Check for oil leaks from the riveting tool	Visual check, if required, fill with acid-free oil, and bleed hydraulic system	Operator	—
Daily after use	Clean riveting tool	With a rag	Operator	—
Daily after use	Oil moving parts	With acid-free oil e.g. ELFOLNA 46	Operator	—
Either throughout the 3 years or after a period of 2000 working hours	Change hydraulic oil	With acid-free oil e.g. DEA Astron HLP 32	Professional	A complete oil change, to be carried out only by a professional

Trouble shooting

Operations, which may be carried out by the operator, are marked with the letter **O** .

Operations, which may be carried out only by an expert person, are marked with the letter **P**



Caution Hazard of accident! In any case, keep the compressed air supply detached till the source of the problem is eliminated.



Attention Material damage! Operations, which have been marked with the letter **P**, must be carried out only by well- trained experts. Deliver riveting tool from overhaul

Any replacement of original spare parts may be carried out only by well-trained experts.



Note After every instance of problem- removal, a thorough functional check must be carried out

Problems	Cause	Solution
Blind rivet is set correctly	<p>Supply of compressed air is too rare</p> <p>Jaws are dirty Jaws are worn out</p> <p>Jaw case and jaw case body are loose</p> <p>Reduction in stroke due to lack of sufficient oil</p>	<p>(O) Check compressed air supply (O) Set the compressed air setting on the maintenance unit at a maximum of 7 bar (O) Clean jaws (O) Change jaws (see “Maintaining the riveting tool”)</p> <p>(O) Tighten the screws/nuts (see “Maintaining the riveting tool”) (O) Check oil quantity and fill up (see “Maintaining the riveting tool”)</p>
Blind rivet can not be inserted	<p>Oil quantity in the system too high</p> <p>Wrong nose piece</p> <p>Nose piece is loose</p> <p>Travel-path of the mandrel is blocked</p> <p>X-value is too low</p>	<p>(O) Check and adapt oil quantity (see “Maintaining the riveting tool”) (O) Change nose piece (see “Operating the riveting tool”) (O) Tighten screws/nuts (see “Maintaining the riveting tool”) (O) Empty riveting tool mandrel collector</p> <p>(O) Reset the value of X (see “Adjusting the jaw case body”)</p>

Trouble shooting

Problems	Cause	Solution
Mandrel is not sucked	Supply of compressed air is too rare X-value is too low Safety valve gets blown off Safety valve is not tight Safety valve is defective	(O) Check supply of compressed air (O) Set the compressed air setting on the maintenance unit at 6 bar (P) If operating pressure is OK, deliver riveting tool from overhaul (O) Reset the value of X (see "Adjusting the jaw case body") (O) Check the setting of compressed air (O) Tighten the safety valve (O) Replace safety valve
Air bubbles in the hydraulic system	Oil level is too low Not bled correctly O-ring is leaking	(O) Check oil level and fill up (O) Bleed the hydraulic unit (see "Maintaining the riveting tool"), change the O-ring if required (P) Deliver riveting tool from overhaul
Stroke is too short	Oil level is too low X-value is too low	(O) Check oil level and fill up (O) Reset the value of X (see "Adjusting the jaw case body")
Loss of hydraulic oil due to leakage	Riveting tool is defective	(P) Deliver riveting tool from overhaul
Safety valve gets blown off	Compressed air pressure is too high Valve is defective	(O) Check and adjust compressed air setting (O) Replace safety valve
Excessive loss of oil from riveting tool	Leaking and worn out O-rings inside the riveting tool	(P) Withdraw the riveting tool from the work-routine, and order an overhaul

Disposing of the riveting tool

Ensure that the hydraulic oil is inside the riveting tool. Dispose it off in an environmentally friendly manner.

Send the riveting tool back to the manufacturer in it's original packing, if still available.

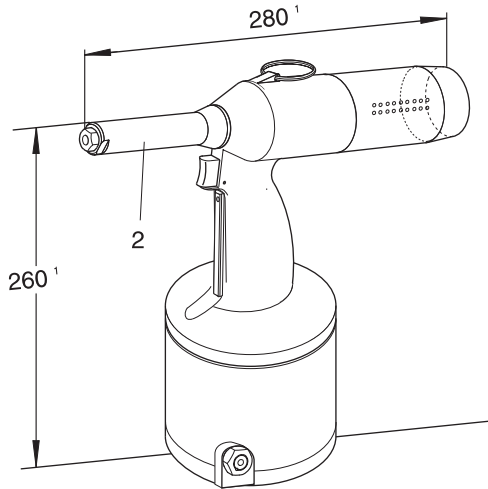

Technical data

Type of riveting tool:	RL 20A
Height:	260 mm ¹
Width:	280 mm ¹
Weight:	1.6 kg ¹
Operating pressure:	5-7 bar
Compressed air supply	
Nominal diameter:	DN 6
Power output (at 6 bar):	approx 13 kN
Operating stroke:	approx. 15,8 mm
Operating range:	Blind rivet-shaft Diameter 2.4 to 5 mm

Sound emission level in the workplace:	$L_{PAI} < 70 \text{ dB(A)}$
Vibration level:	$a_{hw} < 2,5 \text{ m/s}^2$

If desired, the nose cap (2) can also be counted in other measurements.

¹ The length and height and weight measurements of the riveting tool are as per the standard procedures.

Guarantee

Other than the official guarantee (6 months), the company RIVETEC also offers a guarantee of an additional 6 months from the date of purchase. (The bill being the proof thereof).

The following working parts are excluded from the guarantee agreement :

- Jaws (15)
- Nose piece (1)
- Socket head screw (7) with O-ring (8)
- O-rings (5) and (19)
- Jaw case (14)
- Spent mandrel collector (6)

LIST OF PARTS

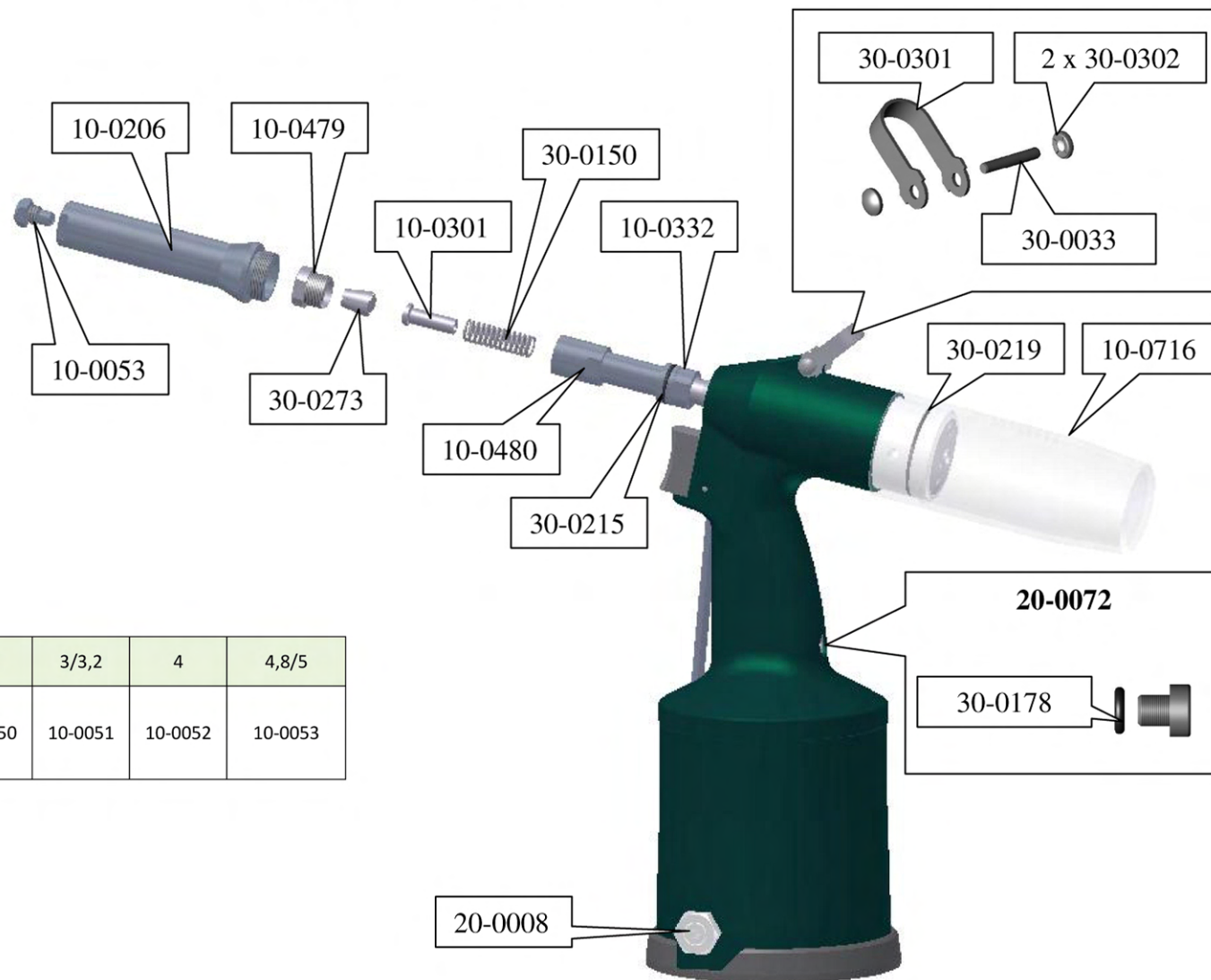

Průměr nýtu / Diameter of Rivet	2,4	3/3,2	4	4,8/5
	10-0050	10-0051	10-0052	10-0053

Accessories for connecting, upkeep, stowage

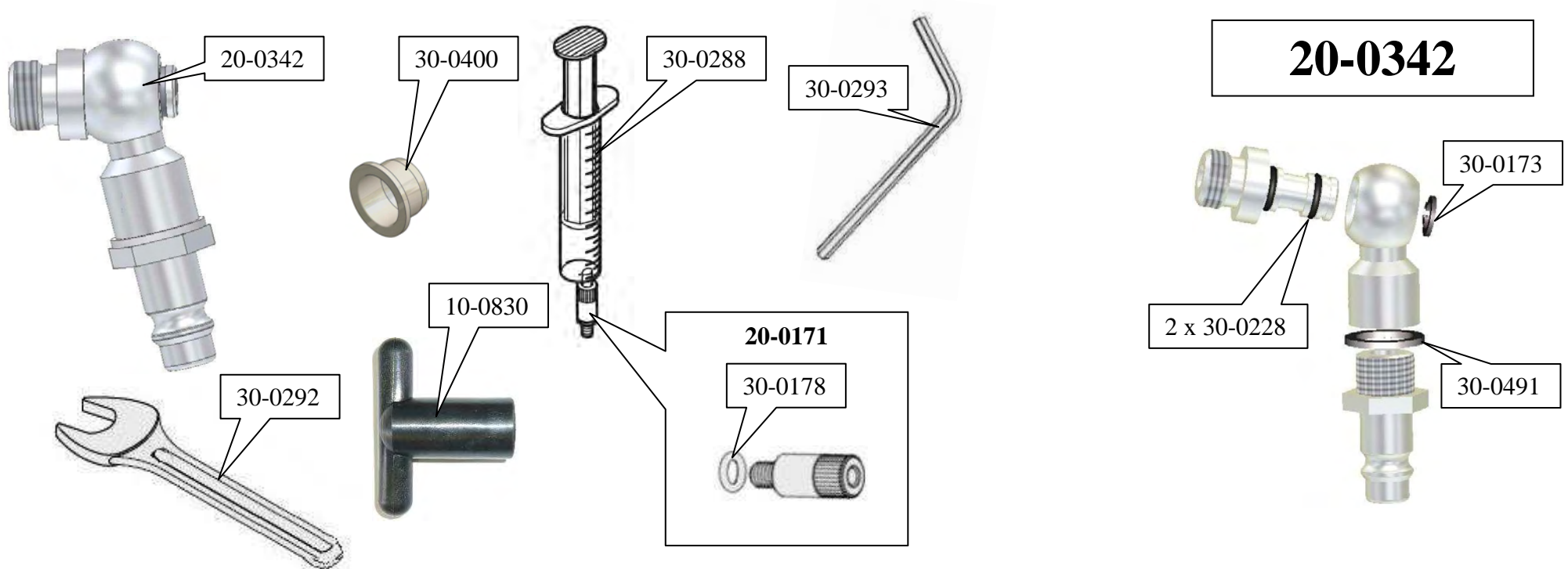

Overview

Note - Please mention the name and the Part No. at the time of ordering.

Objednáací číslo Part No.	Název	Description	Ks Pcs	V
10-0050	Náustek 2.4	Nose Piece 2,4	1	V
10-0051	Náustek 3	Nose Piece 3,0	1	V
10-0052:0	Náustek 4	Nose Piece 4	1	V
10-0053	Náustek 5	Nose Piece 5	1	V
10-0206	Hubice	Nose Cap	1	
10-0301	Vodící trubka	Jaws Pusher	1	V
10-0332	Pojistná matka	Lock Nut	1	
10-0479	Svěrací hlava	Jaw Case	1	V
10-0480	Mezikus	Jaw Case Body	1	
10-0713	Sběrná nádobka	Mandrel Collector	1	V
10-0830	Klíč nástrčný 11	Key SW 11	1	
20-0008	Pojistný ventil komplet	Safety Valve, cpl.	1	
20-0072	Těsnící šroub komplet	Fill Screw cpl.	1	
20-0171	Plnicí šroub komplet	Oil Refill Adapter Screw	1	
20-0342	Vzduchový přípoj - komplet	Swivel-joint, cpl.	1	
30-0033	Kolík válcový 3 x 20	Cylindrical Pin 3x20	1	
30-0150	Pružina tlačná - pod kleštiny	Jaw Pusher Spring	1	V
30-0173	Pojistný kroužek pro hřídele	Retained Ring	1	
30-0178	O-kroužek 5x2	OR 5x2 90 Shore	1	
30-0215	O-kroužek 14.5x1.5	OR 14,5x1,5 70 Shore	1	V
30-0219	O-kroužek 32x2	OR 32x2 70 Shore	1	V
30-0228	O-kroužek 7.1x1.6	OR 7.1x1.6	2	
30-0273	Kleštiny (3-dílné)	Jaws (3-piece)	1	V
30-0288	Stříkačka na olej	Oil Syringe	1	
30-0292	Klíč jednostranný otevřený č.11	Key SW 11	1	
30-0293	Klíč imbusový č.4	Internal Hex Key SW 4	1	
30-0301	Závěs	Lifting Attachment	1	
30-0302	Starlock D=3	Starlock D=3	2	
30-0400	Zátka	Stopper	1	
30-0491	Těsnění 1/4"- bílé	Seal	1	

*V – spare-parts without quarantee

Název produktu:
Product Name:

RL 20A

Kat. číslo:

99-0021

Cat. Number:

Určení produktu:

pneumaticko-hydraulické nýtovací nářadí pro usazování jednostranných nýtů
air-hydraulic riveting tool for installing blind rivets

Specifications:

Výrobce

Manufacturer

RIVETEC s.r.o.

Albrechtice nad Vltavou 16
CZ-39816 Albrechtice nad Vltavou
IČ 60647761

prohlašuje, že výše uvedený výrobek odpovídá následujícím evropským normám a směrnici a byl navržen, vyroben a posouzen ve shodě s platnou legislativou ČR:

declares that the product listed is in conformity with the essential requirements and provisions of following Council Directives and conforms to the following standards:

ČSN EN ISO 12100 Bezpečnost strojních zařízení

ČSN EN 349 Bezpečnost strojních zařízení – Nejmenší mezery k zamezení sřlačených částí lidského těla

ČSN EN 953 Bezpečnost strojních zařízení – Ochranné kryty

ČSN CR 954-100 Bezpečnost strojních zařízení: části řídicích systémů

ČSN EN 983 Bezpečnost strojních zařízení – Bezpečnostní požadavky pro fluidní zařízení a jejich součásti – Pneumatika

ČSN EN 999 Bezpečnost strojních zařízení – Umístění ochranných zařízení s ohledem na rychlosti přiblížení částí lidského těla

ČSN EN 61000-6-1 ed. 2 Elektromagnetická kompatibilita – Odolnost

ČSN EN 61000-6-4 ed. 2 Elektromagnetická kompatibilita – Emise

ČSN EN 60204-1 Bezpečnost strojních zařízení – Elektrické zařízení strojů – Všeobecné požadavky

ČSN EN ISO 13850 Bezpečnost strojních zařízení – Nouzové zastavení – Zásady pro konstrukci

ČSN EN ISO 13857 Bezpečnost strojních zařízení – Bezpečné vzdálenosti k zamezení dosahu k nebezpečným místům horními a dolními končetinami

ČSN EN ISO 1037 Bezpečnost strojních zařízení – Zamezení neočekávanému spuštění

ČSN EN 614-1 Bezpečnost strojních zařízení – Ergonomické zásady navrhování – Část 1

ČSN EN 60439-1 ed. 2 Rozvaděče nn – Část 1

2006/95/ES Elektrická zařízení určená pro používání v určitých mezích napětí

2004/108/ES Elektromagnetická kompatibilita

2006/42/ES Směrnice o strojích a zařízeních

Zákon č. 22/1997 Sb. o technických požadavcích

Zákon č. 71/2000 Sb. (změna zákona č. 22/1997 Sb.)

Zákon č. 205/2002 Sb. (změna zákona č. 22/1997 Sb.)

Zákon č. 226/2003 Sb. (změna zákona č. 22/1997 Sb.)

Zákon č. 102/2001 Sb. o obecné bezpečnosti výrobků

Zákon č. 227/2003 Sb. (změna zákona č. 102/2001 Sb.)

Nářízení vlády č. 18/2003 Sb. o požadavcích na výrobky z hlediska jejich elektrické kompatibility

Nářízení vlády č. 204/2003 Sb. o technických požadavcích na strojní zařízení

Místo a datum:

Albrechtice nad Vltavou

Place and date:

27.11.2008

Jméno, funkce a podpis autorizované osoby:

Ing. Antonín Solfronk
Managing Director

Name, Title and Signature of Authorized Person:





TITGEMEYER Group

RIVETEC s.r.o.
Albrechtice nad Vltavou 16
CZ - 398 16

Tel.: +420 382 206 711
Fax: +420 382 206 719

info@rivetec.cz
www.rivetec.eu