

RIVETEC

TITGEMEYER Group

RIVETING UNIT TIOS H350 TIOS H40

OPERATING MANUAL



TABLE OF CONTENTS

1.	INTRODUCTION.....	4
2.	UNIT USE	5
2.1	Regular Scope and Manner of Use	5
2.2	Expected Operation Level	5
3.	TECHNICAL CHARACTERISTICS.....	6
3.1	Description.....	6
3.2	Technical Parameters	14
4.	WORK SAFETY AND HYGIENE	15
4.1	Introduction.....	15
4.2	Definitions of Terms	15
4.3	Other Safety Statements	16
4.4	Conditions for Unit Use	16
4.5	Organisation Measures	16
4.6	Instructions for Safety during Unit Operation	17
4.7	Warning about Extraordinary Types of Danger	18
4.8	Safety during Maintenance.....	18
4.9	Banned Activities.....	18
4.10	Environmental Protection	19
4.11	Documentation	19
4.12	Warranty	20
5.	STORAGE AND TRANSPORT.....	20
5.1	Storage.....	20
5.2	Transport Instructions.....	20
6.	COMMISSIONING	21
6.1	Installation	21
6.2	Assembly.....	23
6.3	Unit Starting.....	25
6.4	Adjustment and Setting	26
7.	UNIT FUNCTIONS.....	27
7.1	Riveting.....	27
7.2	Riveting Process Evaluation.....	27
7.3	Riveting Operation Control	28
7.4	Riveting Process Data Saving.....	28
7.5	Check and Securing Some Technical Parameters of the Unit	29
8.	OPERATION AND CONTROL.....	31
8.1	Warning:	31
8.2	Two-Part Rivet Riveting Procedure	31
8.3	Procedure of Riveting a Single-Side Ripping Rivet.....	32
8.4	Process Evaluation.....	33
8.5	Internal Control System Panel Button Control	33

9.	MAINTENANCE	35
9.1	Maintenance of the Riveting Head and the Riveting Nozzle	35
9.2	Drive Unit Maintenance	36
10.	OPTIONAL ACCESSORIES	37
10.1	Torn Stud Discharge.....	38
10.2	Set for Connection of a PC with the MP85	38
10.3	Riveting Process Control Box	38
10.4	MMC Memory Card	39
11.	FAILURES AND THEIR REMOVAL.....	39
12.	WEARABLE PARTS	40
13.	SPARE PARTS	42
13.1	Spare Parts Storage	42
13.2	Exchangeability of Spare Parts.....	42
13.3	Ordering Manner:.....	42
13.4	Piece Lists	43
14.	APPENDICES	49
	Hydraulic Diagram	
	Electric Wiring Diagram	
	Oil Technical Sheet	
	Oil Safety Sheet	
	Protocol – Vibration measurement and evaluation	
	ES Declaration on conformity	

1. INTRODUCTION

We present you an operating manual, in which the data and instructions for unit commissioning are stated, as well as the instructions for its operation and maintenance. This documentation is designed for all employees, who come into contact with the unit. It is necessary to pay proper attention to the entire contents because possible lack of knowledge of operation and maintenance may lead to unit failures.

All data stated in this manual and in the documentation handed over together with the unit is the intellectual property of the manufacturer and may be used only for purposes of unit operation. Their abuse for other purposes creates liability according to legal regulations.

The operator is obliged to thoroughly familiarise himself with this operating manual and adhere to the requirements for operation and maintenance.

Unit type: Riveting unit TIOS H350

Riveting head type: TIOS H40

Riveting head production number:

Drive unit type:

Drive unit production number:

Production year:

Manufacturer's address:

RIVETEC spol. s r.o.
398 16 Albrechtice Nad Vltavou
Albrechtice Nad Vltavou 16
Czech Republic

Tel.: +420 382 206 711
Fax: +420 382 206 719
www.rivetec.eu
E-mail: info@rivetec.cz

Further information:

Warning safety symbol:



This warning safety symbol informs about important safety communications in this operating manual. Whenever you see this symbol, read the following communication and information carefully. Inform other operators.

 TITGEMEYER Group	OPERATING MANUAL RIVETING UNIT TIOS H350 TIOS H40	Page 5
Prepared by: A. Solfronk		

2. UNIT USE

2.1 Regular Scope and Manner of Use

The riveting unit is designed for riveting of ripping rivets, both single-side and multi-part (SRB), namely up to the max. stud dimension – diameter 6.8 mm and the max. force needed for breaking 30 kN. The unit is designed for use in production halls with a temperature range of 15 to 28 °C. The unit allows for checking and evaluating the riveting process. The unit can be operated separately or connected with another unit using a connector.

2.2 Expected Operation Level

Work with the unit may only be performed by persons meeting the legally determined age and health competence. Only demonstrably trained, informed, and operator authorised persons may work with the unit. Upon agreement, the manufacturer may perform training of the persons. The operator must clearly determine the scope of work for persons performing the operation, preparation works, maintenance, and repairs.

Maintenance works and repairs of the unit may be performed only by employees, who meet:

- Expert education with experience in the field
- Perfect knowledge of all safety regulations related to the performance of the requested work

3. TECHNICAL CHARACTERISTICS

3.1 Description

The unit consists of the drive unit (4), the riveting head (3), riveting nozzle (2) and connecting hoses (1).



 The riveting nozzle that is fastened to the riveting head, they must correspond to the rivet to be riveted. The connecting hose serves for connecting the riveting head with the drive unit and at the same time allow for increasing the action radius of the operator. The drive unit serves as a source of pressure oil for riveting head drive and at the same time it secures control, checking, and evaluation of the entire riveting process.

3.1.1 Drive Unit Description

The drive unit consists of the base frame (1), the catch bath (2), the electric switchboard (3), and the hydraulic aggregate (4).

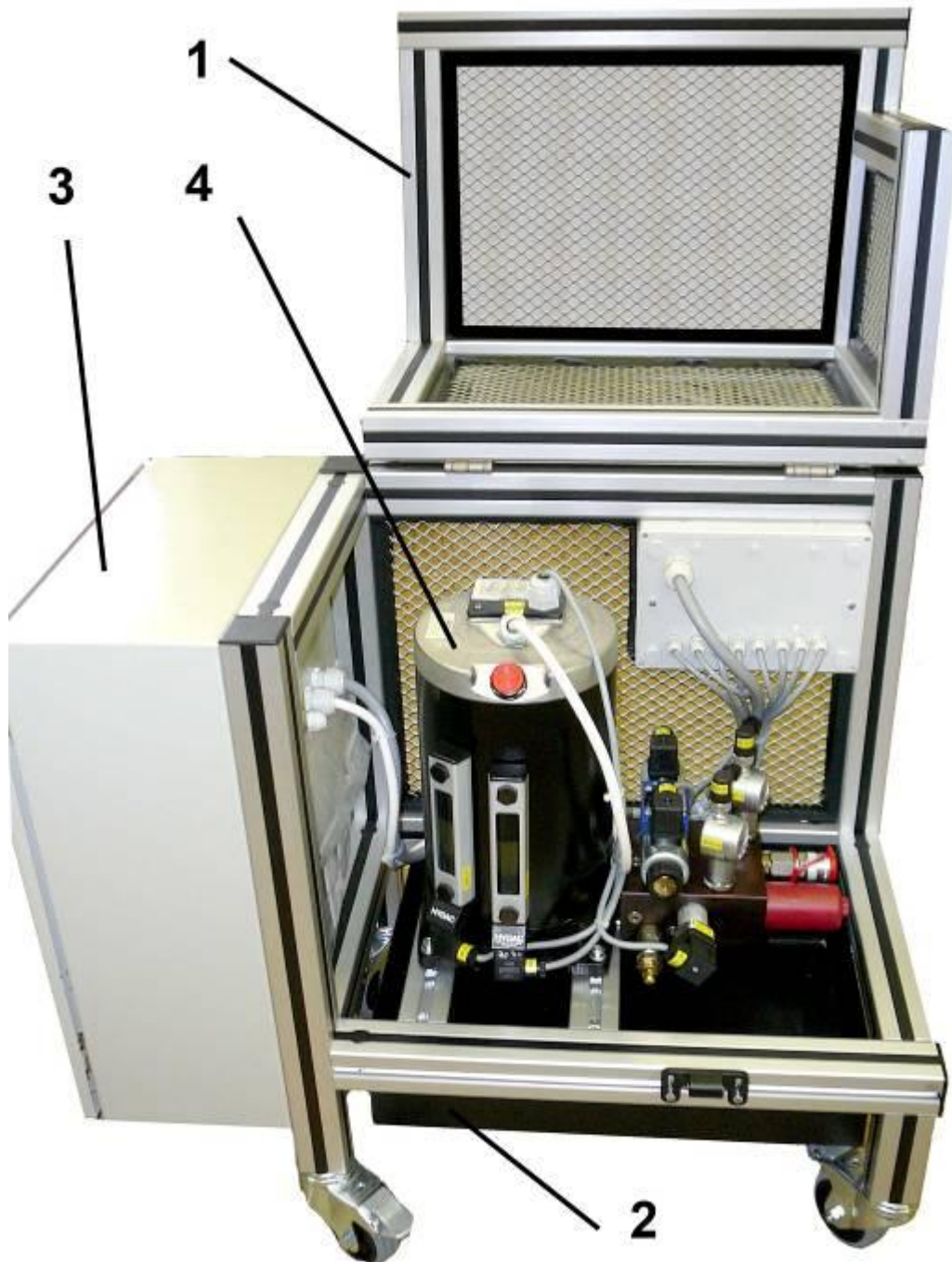

3.1.1.1 Electric Switchboard Description

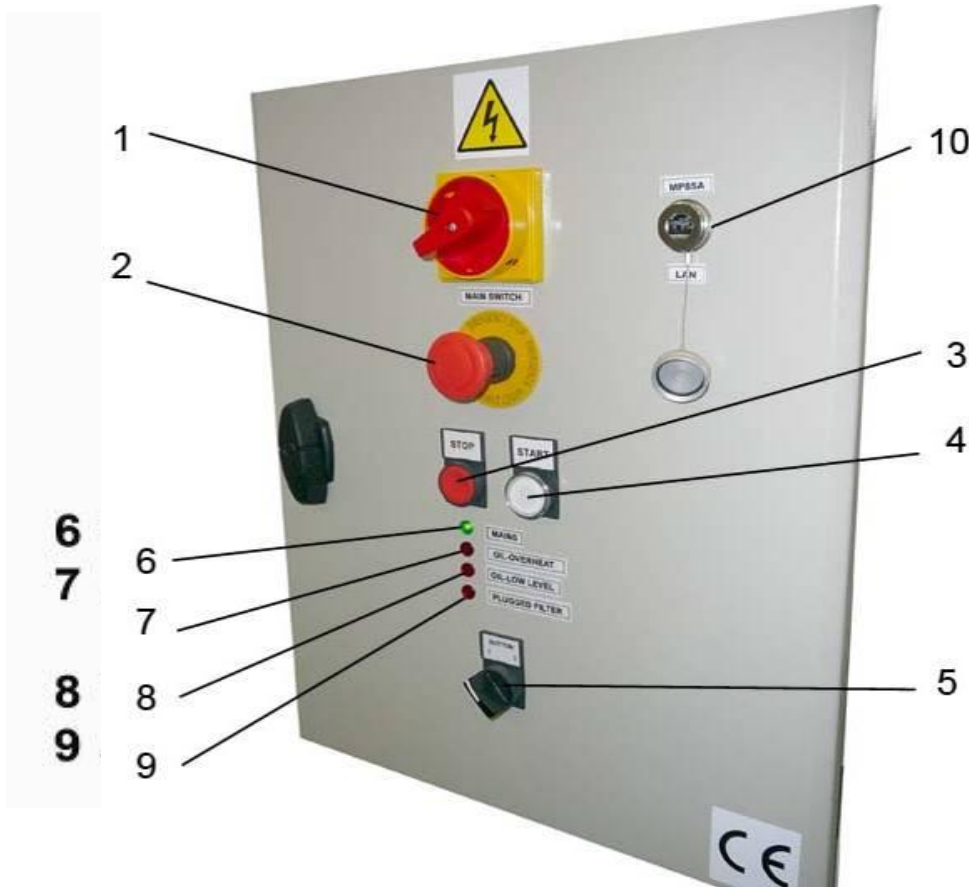

Power control light (6), main switch (1), central STOP (2), aggregate start (4), aggregate stop (3), button switch (5) – serves for activation of the corresponding button at the riveting head, oil overheating control lamp (7), low oil level control lamp (8), filter fouling control lamp (9), LAN (10).

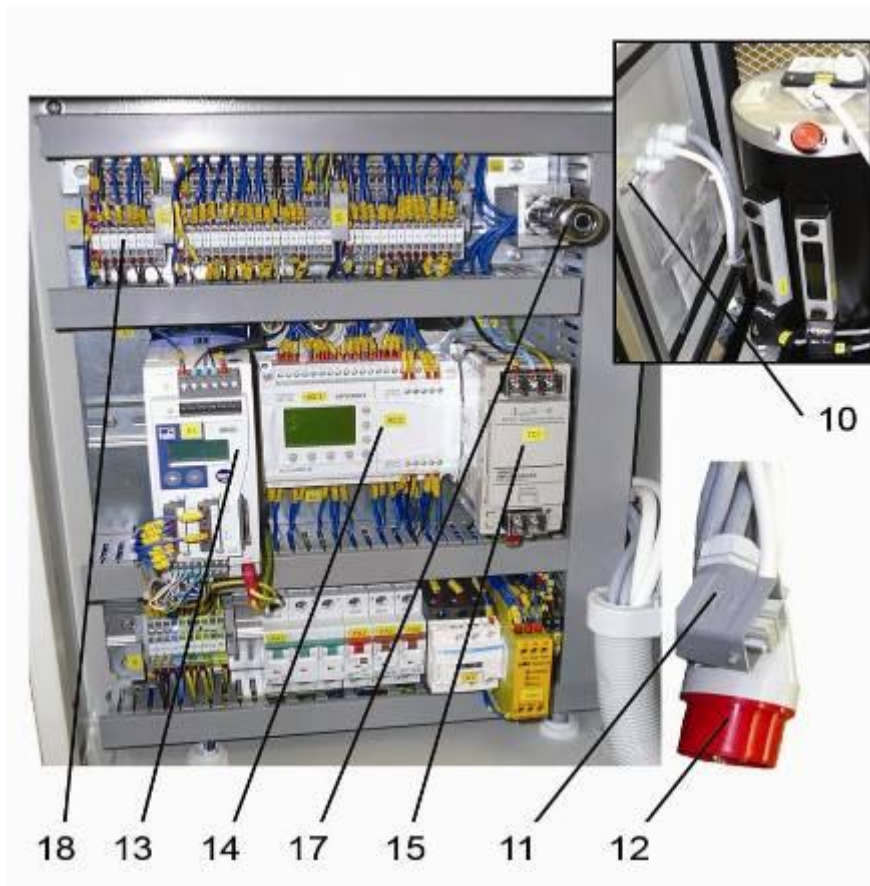

Riveting head connecting connector (10), cable with a connector for connecting an external SPS (11) – allows for connecting with the control system of another unit and signal exchange, cable with the power socket (12), control programmable unit (14) – controls the entire process of riveting, amplifying and evaluation unit MP85 (13) – checks and evaluates the riveting process and at the same time allows for storing the results and their transfer into the PC, supply unit 24 V (15), socket for servicing buttons (17) – serves the servicing technician when adjusting and repairing the unit, base terminal board (18).

3.1.1.2 Hydraulic Aggregate Description

(0010) A compact unit consisting of an electromotor submersed in oil that drives the self-intake valves controlled by a radial piston pump with three pistons located in the aggregate base. The oil tank surrounds the motor and the pump – at its upper side, there is a motor terminal board and the venting filter. At the tank side, there are two level gauges with switches that show the oil level and signal the minimum.

At the base side, there is a control block fastened (0020), comprising of the following elements: filter (0030) wither filtering insert (0040) and electric signalling of clogging (0050) for securing oil filtering, securing valve (0060), using which the max. value of operating pressure is set. The switchboard (0090) is a three-position four-way one – for controlling the oil flow direction with a relieving function in the middle position. Electronic pressure switches (0070) placed at the outlets have the task of signalling the pressure course.

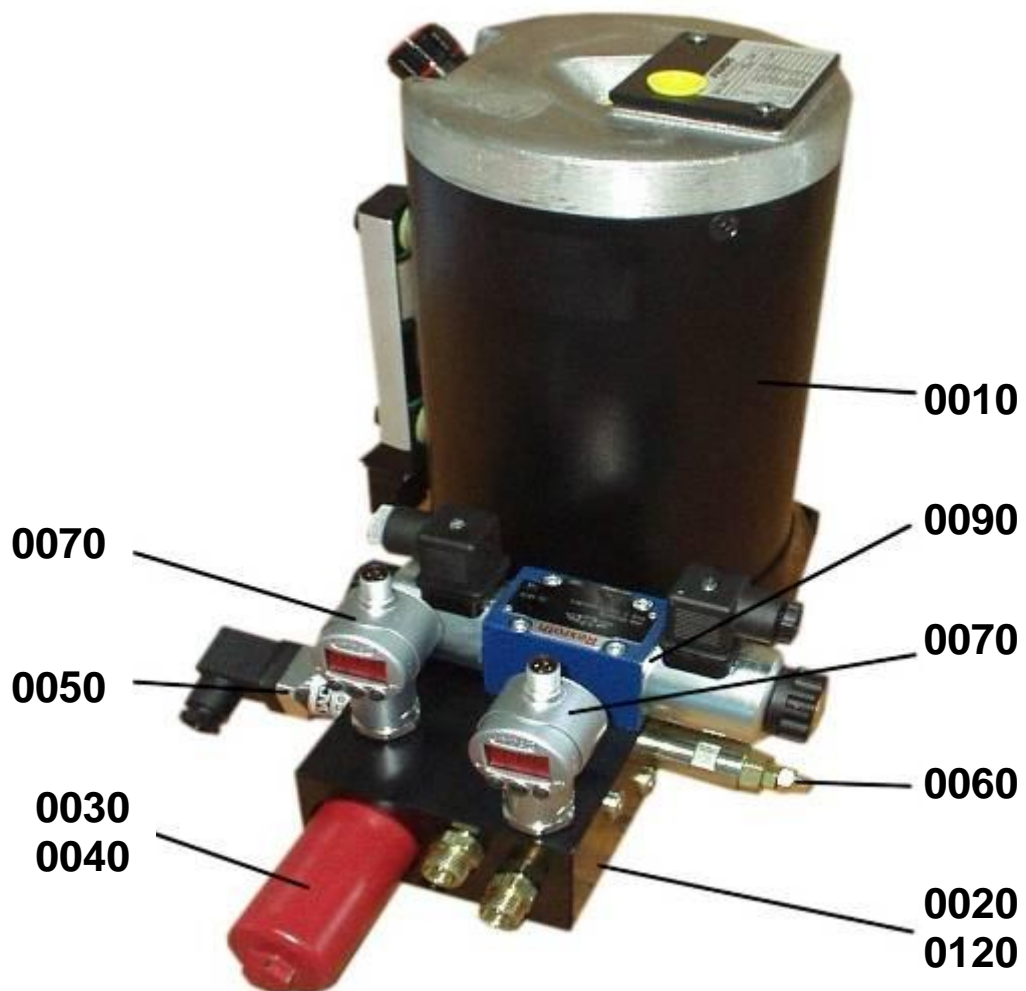

The aggregates may only be operated in a short-term operation S2 or an interrupted operation S3 (according to VDE 0530). They are not suitable for permanent loading with the working pressure. Overheating may cause motor burning or plastic part melting. Besides that, there is also the danger of injury! The aggregate contains thermal protection of the motor.

3.1.2 Riveting Head Description

The riveting head is a hand instrument, whose piston is driven in both directions by hydraulic oil. The riveting head is connected with the pressure oil source by hydraulic hoses (3) ended with quick couplers (1). The riveting head is equipped with force and distance sensors for evaluating the course of the riveting process. A part of the riveting head is the setting chip (2) that serves for storing the setting parameters and their use for connection to the amplifying and evaluating module. The riveting head is equipped with two starting buttons (4), which allows the operator to hold the head ergonomically in all positions. The riveting head may be suspended on a balancer. The head is standard equipped with a rubber extension for catching torn off studs, it is also possible to equip it with different unit for discharge and catching of torn off studs, see Optional accessories.

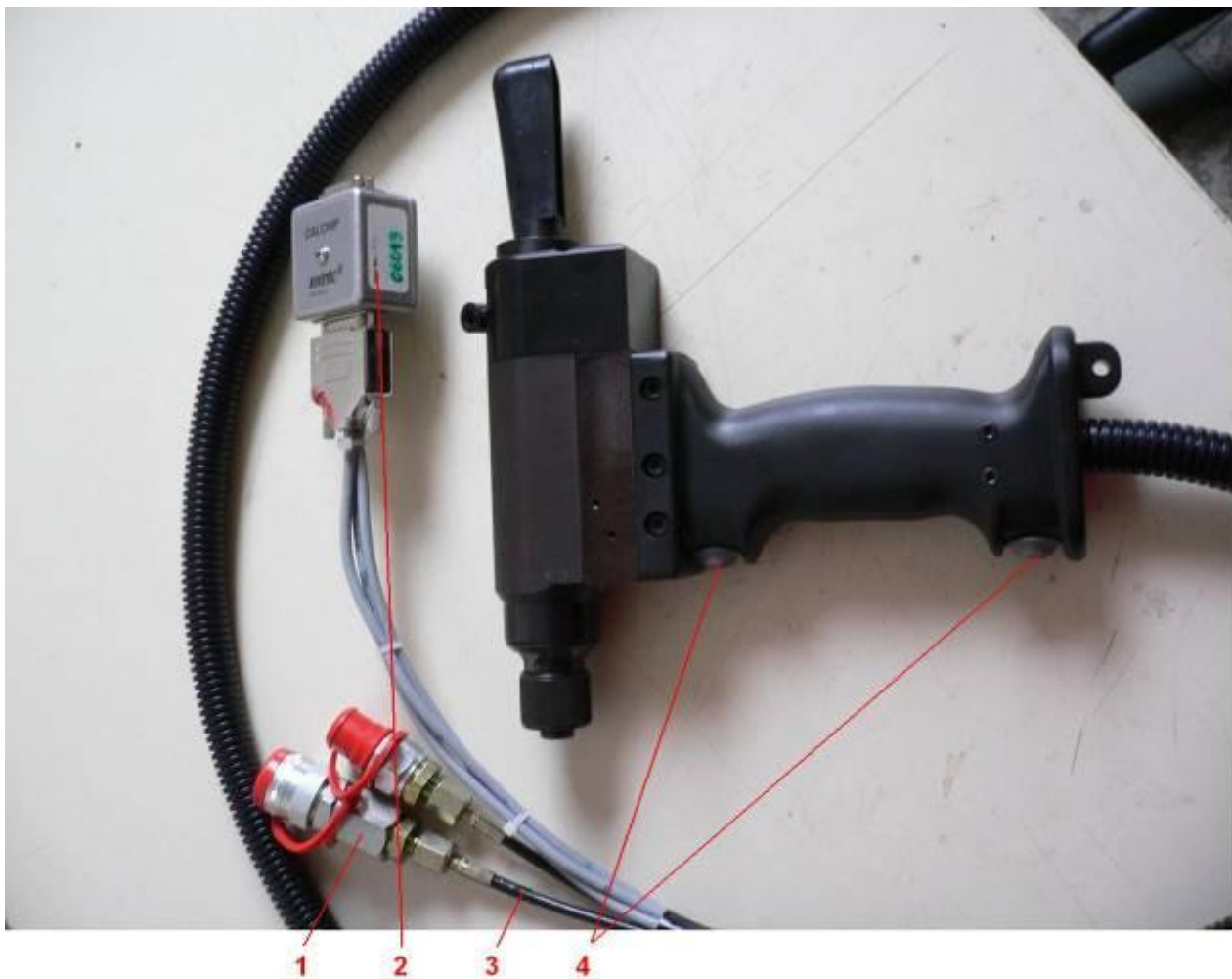

To the riveting head, it is possible to mount various types of riveting nozzles for various types of rivets. The limiting factor when choosing is the opening diameter in the hydraulic piston of the riveting head, the dimension of the connecting threads and openings, and the force needed for rivet tearing off. In case of any doubt, it is necessary to address the authorised service or the manufacturer.

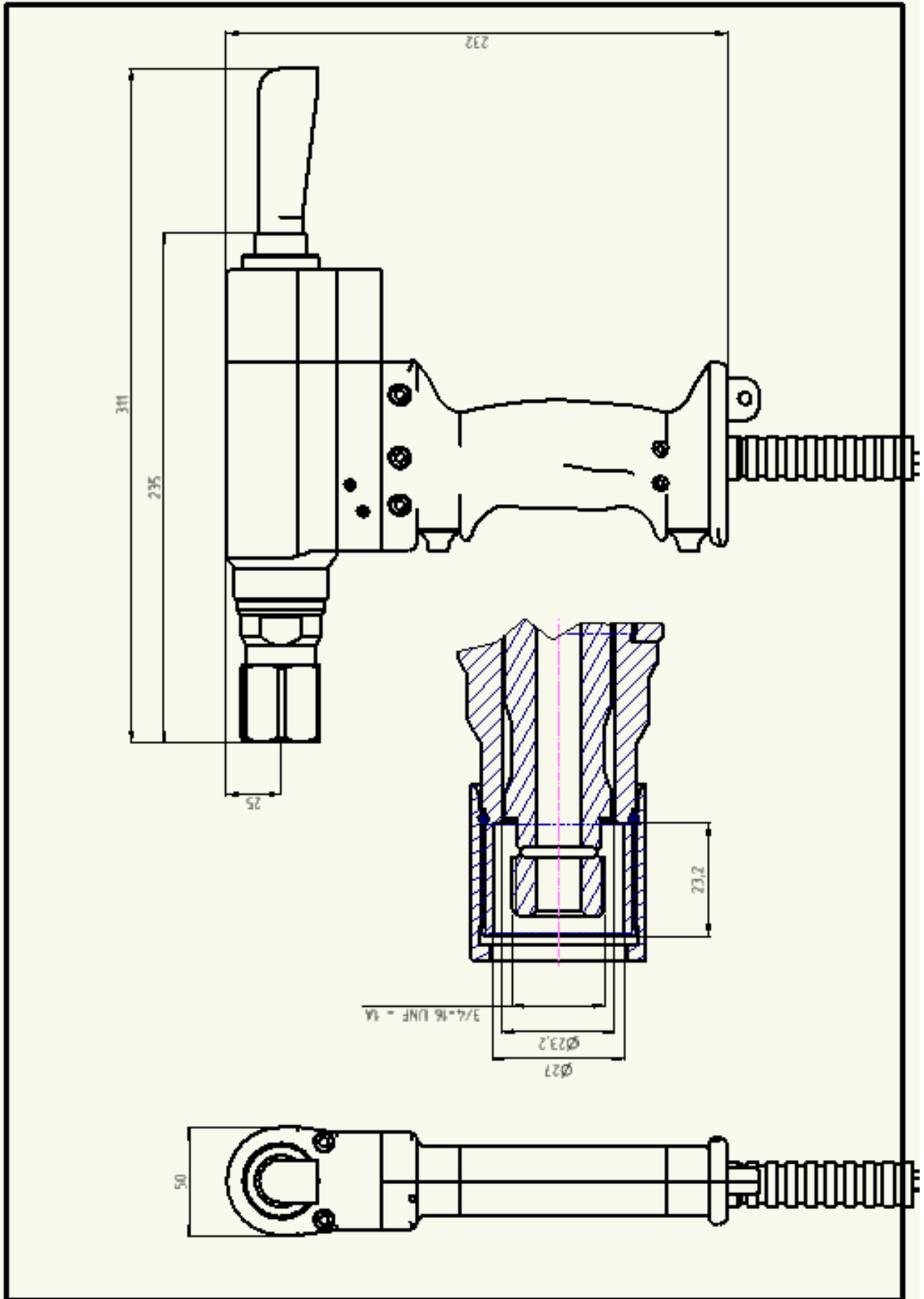

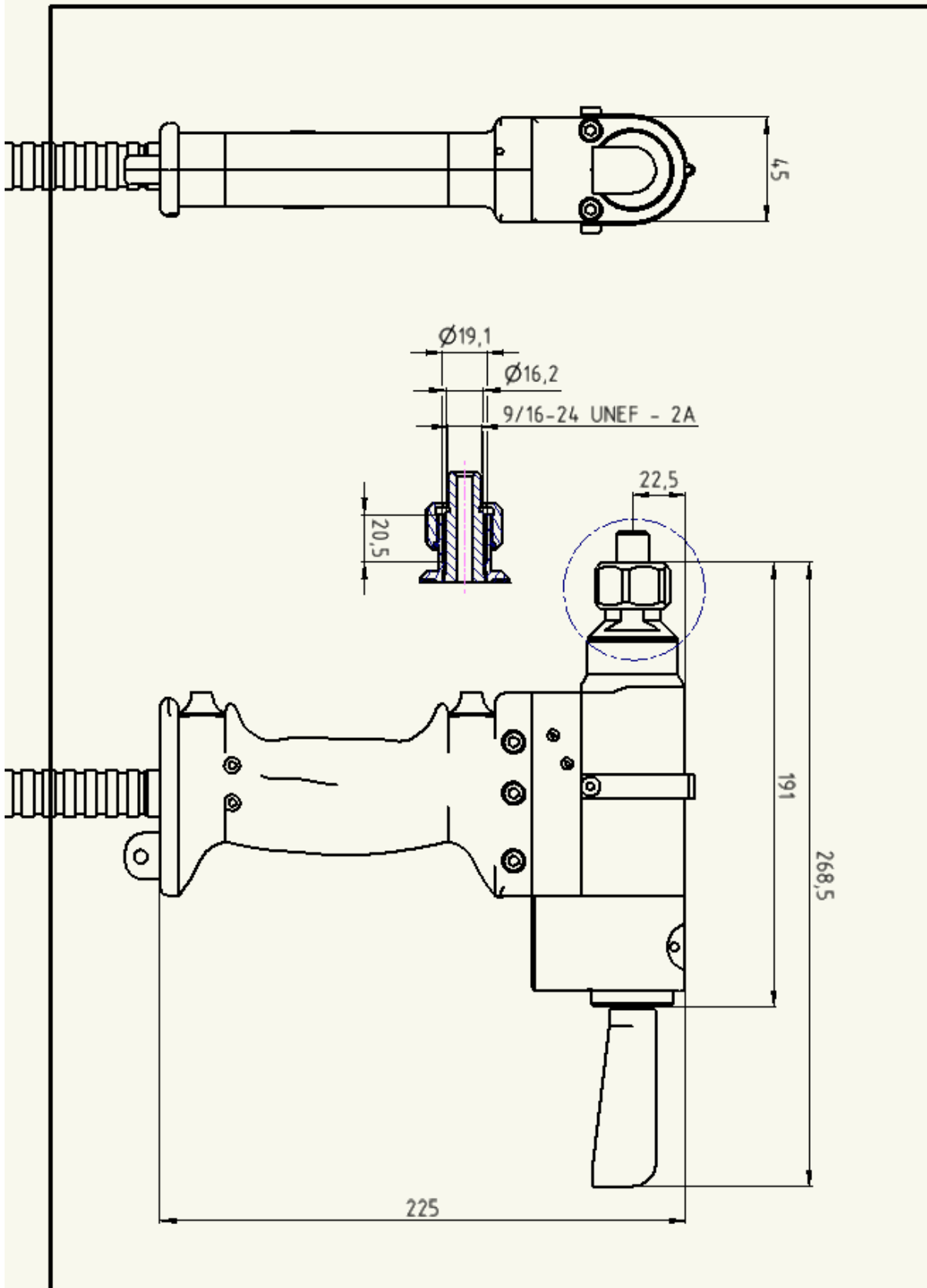

3.1.3 Connecting Hose Description

The connecting hoses are designed as a complete set. They are fitted at both ends with hydraulic quick couplers and the set contains also an electric cable fitted from both sides with connectors. The connecting hoses have a length of 2.5 m. Other lengths are possible upon agreement with the manufacturer.



3.1.4 Riveting Nozzle Description

The riveting nozzle consists of at least the following parts: jaws (1), clamping head (2), front nozzle (3). There may be more parts – depending on the rivet type to be used with the nozzle and the nozzle manufacturer.



3.2 Technical Parameters

PARAMETER	UNIT	VALUE
Working fluid	Mineral hydraulic oil of class VG 32 according to ISO TC 28/SC4 (DIN 51524) with viscosity 32 mm ² /s at 40 °C	
Tank volume	dm ³	4
Working fluid purity according to	ISO 4406 NAS 1638	18/16/13 7
Max. securing pressure	MPa	35
Pump flow rate	l/min	1,0
Working fluid temperature range	°C	40÷55
Motor output	kW	1,6
Connecting voltage	V/Hz	400/50
Control voltage	V	24
Pulling force of the riveting head	kN	30,7
Riveting head piston stroke (max.)	mm	30,5
Riveting head weight	kg	3,7
Drive unit weight	kg	85
Drive unit dimensions	mm	780x400x660

4. WORK SAFETY AND HYGIENE

4.1 Introduction

These safety instructions were prepared in accordance with the governmental directives:

No. 24/2003 Coll. (Technical requirements for machinery)

No. 17/2003 Coll. (Technical requirements for electric low voltage unit)

No. 18/2003 Coll. (Technical requirements for products from the standpoint of their electromagnetic compatibility)

4.2 Definitions of Terms

Machine user (machine operator)	- It is a physical or legal entity responsible for the machine operation and its technical condition, adherence to the work safety standards and corresponding national standards for machine operation.
Responsible person	- It is a person authorised by the user to check the machine operation and its technical condition, adherence to work safety standards and corresponding national standards for machine operation.
Maintenance	- A person or persons, whose task is transport, installation, repairs, and maintenance or cleaning of the machine.
Adjuster	- A person or persons, whose task is machine or tool adjustment.
Operator	- A person or persons, whose task is regular operation of the machine.
Dangerous space	- Any space inside or outside the machine, in which the person is exposed to danger, injury or health harm.
Dangerous points	- These are points on the machine with danger of injury or health harm.
Unit repair	- This means a product repair with a minor or even significant wear, where the nature of the repair does not change the original parameters and safety of the unit.

4.3 Other Safety Statements

- All defects and failures that occurred must be reported to the shift leader and recorded into the Operating book of the unit including the manner of repair securing.
- Machine user is obliged to train the employees for operation, adjustment, and maintenance of the unit, he is obliged to periodically train and check. He must record every instruction into the journal with signatures of interested persons.
- Operation and maintenance must be performed according to the manufacturer's regulations.
- The space, in which the unit is installed, must be equipped with anti-fire unit and the operator must be perfectly familiar with it. It is necessary to adhere to the safety regulations for flammable and oil substances valid for the country, where the unit is operated.

4.4 Conditions for Unit Use

4.4.1 Technical Condition

- The unit may only be used in a perfect technical condition.
- The operator is obliged to continuously ascertain this condition.
- The found failures, especially such that can adversely affect safety, must be removed immediately.
- Protective devices must be always functional and in a perfect technical condition – see chapter □ Protective devices (p.15)
- Protective Devices
 - Securing valve as protection against overload
 - Current securing of the electromotor
 - Central STOP

4.5 Organisation Measures

4.5.1 Obligations of the Machine Operator

- The operator of the unit must prepare an Unit Record with the dates of checks, the list of checked unit parts, and the list of persons to perform the checks are determined, with regard to the operating manual.
- The operator of the unit must maintain the unit in a perfect condition and order at the workplace.
- Works on the unit may be allowed by the operator to be performed only by competent persons, who were properly trained and instructed.
- The operator must adhere to the legally determined minimum age of the operator, maintenance, and adjusters.
- The operator of the unit must secure expert checking (review) of the production unit, especially its safety devices, namely:
 - Before commissioning into regular operation
 - At least once a year - after changes or repairs

 <small>TITGEMEYER Group</small>	OPERATING MANUAL RIVETING UNIT TIOS H350 TIOS H40	Page 17
Prepared by: A. Solfronk		

4.5.2 Adherence to Regulations

The operator of the unit must take care about adherence to the corresponding safety regulations in order to secure safety of persons, who have the task of operating, maintaining, and repairing. The operator must check the persons coming into contact with the unit for adherence with safety regulations.

4.5.3 Personal Protective Unit, Tools

If a regulation or necessity requires, the employees must use personal protective unit and tools. The operator must check this adherence to regulations.

4.5.4 Failures

Should failures occur in the unit that would endanger the safety of operation or if there is doubt about the perfect condition of the unit during operation, it is necessary to stop the unit immediately and remove the failure. The failures must be removed only by trained and authorised employees by the unit operator.

4.5.5 Machine Modifications

Without the supplier's consent, no modifications of the design nature that would affect safety worsening may be performed on the unit. This measure applies also for welding works on bearing parts.

4.5.6 Spare Parts

It is necessary to use only such spare parts that meet the determined requirements of the manufacturer. Inexpertly performed repairs as well as use of incorrect spare parts results in voiding the product warranty. Use of an incorrect spare part is considered to be an intervention into the machine structure. The manufacturer therefore does not accept liability for such modified structure.

4.5.7 During Long-Term Unit Shutdown:

- Turn off the control voltage.
- Turn off the main voltage supply.

4.6 Instructions for Safety during Unit Operation

4.6.1 Obligations of the Operator during Regular Operation



The operator must observe the operating conditions. Adhere to all safety regulations and standards. Familiarise with the operating manual.

Before every commencing of work with the unit, make sure and continuously check, that no unauthorised person is present near dangerous points. During failures of function of the unit, immediately stop and prevent its starting, until the failure is removed. During work with the unit, use protective tools, e.g. protective gloves, hearing protectors, possibly other PE with regard to the performed operation.

4.6.2 Regular Operation of the Unit

- Avoid all manners of work that are in conflict with safe operation.
- Report changes during operation immediately to corresponding persons, possibly immediately stop and secure the unit.
- Start the unit only after removing the failure cause.

4.6.3 Preparation, Adjustment

- Perform preparation works and function verification only by a qualified person only in the ADJUSTMENT mode.
- During preparation and adjustment, take increased care because the interlocking and protective devices securing protection of the unit and the operator are inactive in the ADJUSTMENT mode.

4.7 Warning about Extraordinary Types of Danger

4.7.1 Electricity

The description is in this entire operating manual.

4.7.2 Dangerous Points



Dangerous points are the places, where upon non-adherence to the safety regulations, damage of the property or danger to personal health may occur.

Dangerous points are especially:

- Moving parts of the unit
- The working space of the unit
- Moving supplies
- Hose connections

Other dangerous places may arise according to the type of the operated technology at the unit. These dangers must be stated in the manual supplied by the technology operator.

4.7.3 Danger during Handling of Fire

- The working fluid – hydraulic oil is a flammable liquid with the flashpoint of about 200 °C.
- Works on the unit, such as welding, burning or grinding, may only be performed by an authorised person.

4.7.4 Noise

It is necessary to use the prescribed protective tools against noise.

4.8 Safety during Maintenance

- Screw connections, flanges or valves may be tightened only when the pipelines are not pressurised.
- Repairs and failures must not be removed at the unit under voltage and under oil pressure. It is necessary to turn off the unit and depressurise hydraulic circuits.
- During all maintenance or repair works, adhere to valid regulations for environmental protection.

4.9 Banned Activities



To perform any repairs under voltage and pressure of oil.

To remove and disable the safety devices and devices for signalling of failures and interlocking the machine operation or disconnect them electrically.

To operate the unit by persons younger than permitted by legal regulations for operation of this unit in the operator's country. The record of their training must be in writing.

To fill the unit with other than recommended operating substances with worse than prescribed purity.

To perform any welding works on the drive tank and the hydraulic pipeline.

To perform any repairs on the unit with non-depressurised hydraulic circuits and under voltage.

To handle open fire near hydraulic unit.

It is forbidden to perform any such design modifications and interventions that have not been recommended and approved by the unit manufacturer. The same applies to replacement of spare parts for another type or kind.

To perform any repairs without the supervision of a trained maintenance employee and consent of the responsible manager.

Only a person trained for this activity may remove failures on the electrical installation and electrical unit.

4.10 Environmental Protection

- During all works on the unit, it is necessary to adhere to the valid regulations about environmental protection.
- During the replacement of hydraulic oil and filtering elements, it is necessary to adhere to the regulations concerning their disposal with regard to local conditions.
- During disposal of waste, it is necessary to consider the possible health risks and compatibility with the environment.
- Upon a hydraulic oil leak, it is necessary to stop the operation immediately and proceed in accordance with the regulations for removal of effects of the emergency with oil products. New starting and performance of the instructions for operation are to be implemented only after removing the emergency causes!

4.11 Documentation

- The accompanying documentation complies in its design with corresponding standards and regulations valid at the time of the commissioning.
- The documentation contains all documents for operation and maintenance of the unit.
- The operator must ensure that there is at least one printout of the documentation accessible to the group of employees securing operation, adjustment, and maintenance of the machine.

Every person that is authorised to perform an activity on the machine is obliged to familiarise itself with the contents of the technical documentation (the operating manual) before commencing work.

4.12 Warranty

The manufacturer guarantees for supply defects according to the conditions agreed in the contract. The warranty period applies according to the contractual provisions. The warranty does not apply to damages caused by inexpert handling of the unit, use of unoriginal spare parts or upon non-adherence to the instructions stated in the operating manual. Non-adherence to safety instructions, especially ignoring forbidden activities prevent the manufacturer's liability.

5. STORAGE AND TRANSPORT

5.1 Storage

The storage premises must be dry and dust-free with low air humidity.

Acid or other chemical vapours must not be present. For storage longer than 6 months, it is necessary to properly conserve using conserving oil.

Store rubber parts in polythene bags and conserve with glycerine. Prevent access of ultraviolet radiation and humidity.

Spare parts (if the products contains them) are packaged according to the belonging to functional subgroups.

Clear arrangement of spare parts and their storage is a prerequisite of well working maintenance.

Lightly coat the riveting head and the riveting nozzle with conserving oil during long-term storage (e.g. ELFOLNA 46).

5.2 Transport Instructions

The unit is supplied completely assembled. From the manufacturer, it is transported without the working fill – the oil is drained.

5.2.1 Instructions for De-conserving

Conserved parts must be rid of conserving and all pollutants.

All inhibitors of rust, if they were used during transport and storage, must be removed. The inhibitors, if washed out with warm oil, cling and accumulate on the polished areas of the unit (pumps and hydro motors).

5.2.2 Dimensions and Weights of the Unit

PARAMETER	UNIT	VALUE
Unit weight	kg	90
Max. dimensions - plan - height	mm	780 x 400 660

6. C

OMMISSIONING

6.1 Installation

- The unit must be unpacked from the transport material and established in place, where it will be operated.
- The hydraulic aggregate must be filled with the operating fluid. Fill with a fluid prescribed by the unit manufacturer, namely in a volume of 4 litres. For filling, use the filling opening located at the top side of the aggregate.
- The maximum of the oil fill may be checked using the checking probe located on the closure – see the figure. The quality and cleanliness of the oil fill must correspond to the requirements of the regulations stated in Chapter Technical Parameters (p.13).

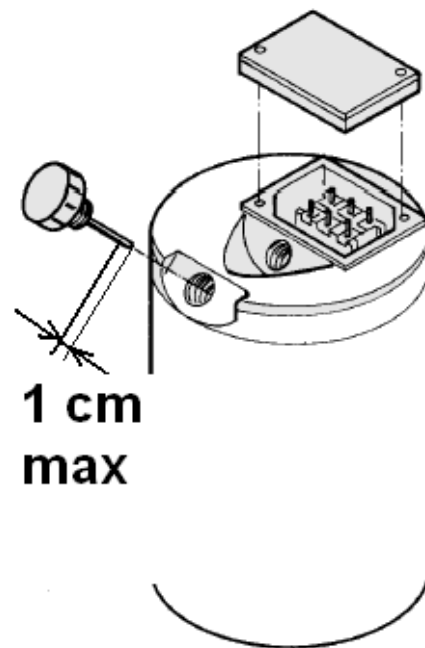

6.1.1 Conversion Table for Hydraulic Mineral Oils

Performance class according to ISO-TC 28-SC4, CETOP RP91H HM
 according to DIN 51 524 part 2. HLP

VISC. GRADE (ISO)	VG 32	
ADDINOL	HYDRAULIKOL HLP 32	
AGIP	OSO 32	
ARAL	VITAM GF 32	
BENZINA	OH-HM 32	
BP	ENERGOL HLP 32	
CASTROL	HYSPIN AWS 32	
DEA	ASTRON HLP 32	
ELF	ELFOLNA DS 32	
ESSO	NUTO H 32	
FINA	HYDRAN C 32	
FUCHS	RENOLIN B 10 RENOLIN VG 32	
KORAMO	MOGUL HM 32	
MOBIL	DTE 24 HYDR.OIL. LIGHT	
MOL-LUB	MADIT OH-HM 32	SUPPLIED FOR THE UNIT BY THE MANUFACTURER
OMV	HLP 32, HYD HLP 32	
PARAMO	PARAMOL HM 32	
SHELL	TELLUS OIL 32	
TEXACO	RANDO OIL HDA-32	
TOTAL	AZOLLA ZS 32	
VALVOLINE	ULTRAMAX HLP 32	

This table is compiled based on the documents and catalogue sheets of oils and does not guarantee the quality or miscibility of oils from individual producers. The use of oils must be consulted with the unit manufacturer.

As standard, oil MADIT OH-HM 32, whose **technical sheet** and **safety sheet** forms an appendix of this manual, is supplied with the unit.

6.2 Assembly

6.2.1 Mount the riveting nozzle on the riveting head:

- First check, whether the hydraulic piston is in the front initial position (see the figure).

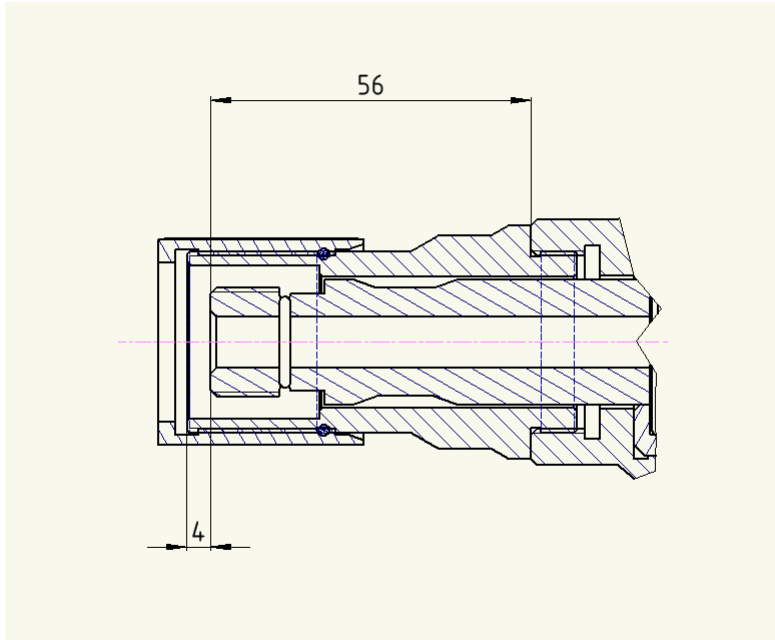

- Into the clamping head (1) insert the jaws (2), then turn the clamping head on the thread of the hydraulic piston. Then secure the clamping head (1) and tighten.
- Use the wrench A – 13 mm for tightening and wrench B – according to the clamping head.
- The tightening torque – 12 Nm.

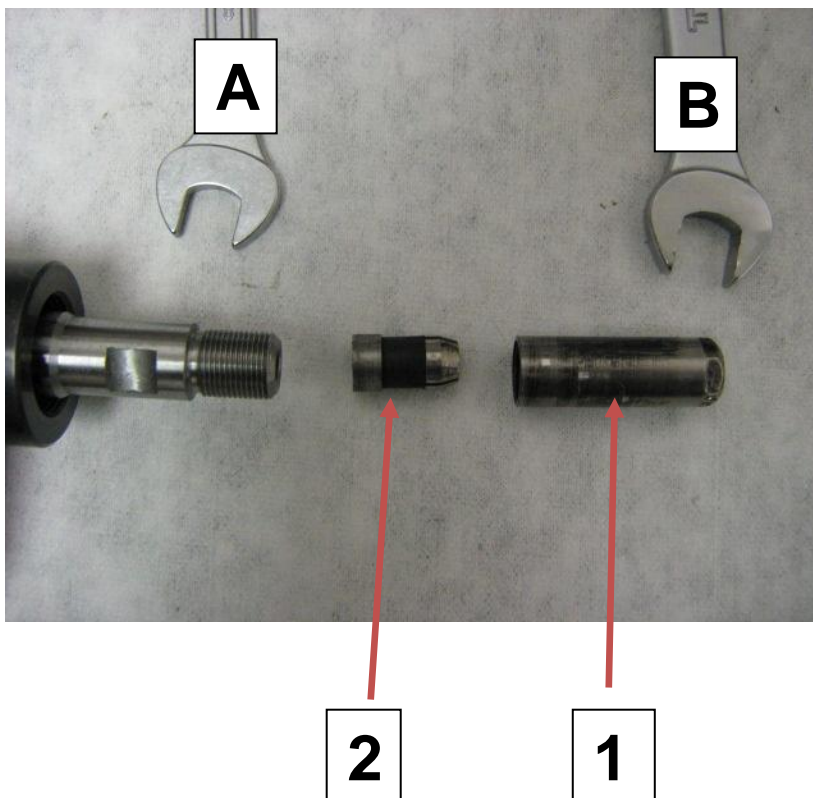

Prepared by: A. Solfronk

- Screw the nozzle on (5) and tighten using wrench 22. Tightening torque 20 Nm.

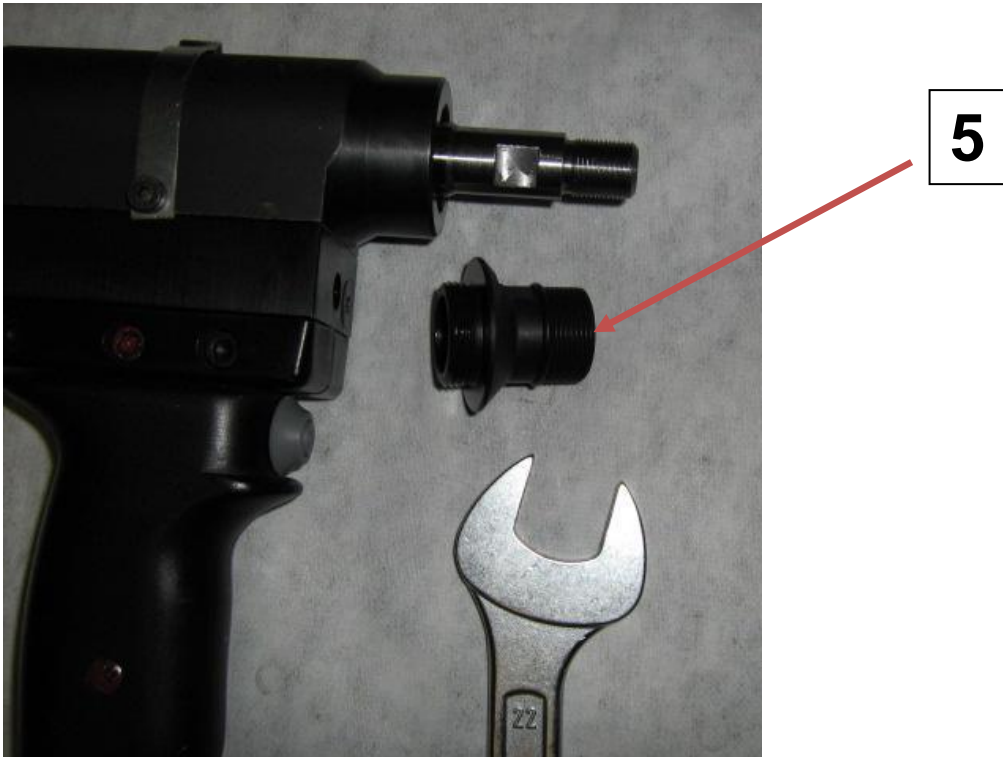

- Into the nozzle (5) insert the front nozzle (3) and tighten the sleeve nut (4) at 8 Nm.

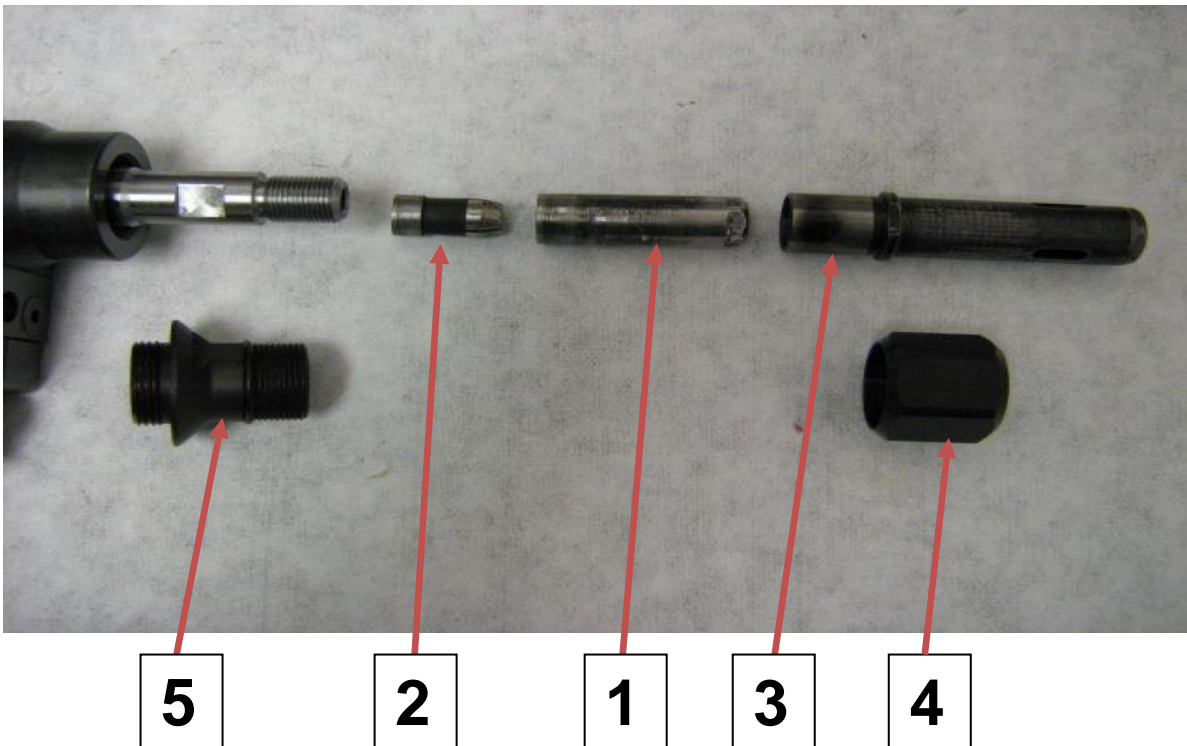

6.2.2 Connecting the Riveting Head and the Drive Unit

- Connect the hydraulic quick couplers of the riveting head into the quick couplers of the drive unit, in case of using connecting hoses, connect the quick couplers of the riveting head and the connecting hoses first and then the quick couplers of the hydraulic hoses and the drive unit.

In the same manner, perform the connection of the connectors (setting chip) of signal transfer, for connecting the connectors, perform their securing.

6.2.3 Connecting an External SPS

- Using the connector, connect with an external SPS.
- For the type of the connector and individual signals see Appendices – “Electric wiring diagram”

6.2.4 Connecting the Unit to the Electricity Source

- The unit is equipped with a 5-pin plug 16A / 400V.
- The supply conductor is 3 m long.

6.3 Unit Starting

- By pulling and turning, unblock the central STOP (3).
- Turn on the main switch (2) – the power control light is lit (1).
- After 10 s, turn on the START button (4).
- Perform the starting button selection using the selector switch (6).



6.4 Adjustment and Setting

6.4.1 Adjustment of the Riveting Head and Entering the Values into the Setting Chip

All actions connected with adjustment of sensing elements on the riveting head and saving their setting data into the setting chip are performed already in the production plant. These actions are subject to internal regulations of the RIVETEC Company and are documented for the customer by the "Test Protocol" that is supplied to the riveting head.

Any adjustment and setting may only be performed by a competent person – authorised service.

6.4.2 Setting the Working Values of the Hydraulic Aggregate

All settings at the hydraulic aggregate are performed in the production plant. The procedure and manner of adjustment corresponds to the procedures of the supplier of the hydraulic unit and the setting values are governed by the internal regulations of the RIVETEC Company so that the required and declared output parameter of the unit are achieved. See Chap. 3.2 Technical Parameters.

Any adjustment and setting may only be performed by a competent person – authorised service.

6.4.3 Program and its Setting in the Control Programmable Unit

The control programmable unit is equipped with a program already in the production plant. The program is built so that the unit allows for using all functions described in Chapter 7. Unit Functions. The program is password protected so that its breach cannot occur. The safety password is stored at the manufacturer. A copy of the original program is stored on a CD and attached to the operating manual as an appendix.

Any program changes and program settings may only be performed by a competent person – authorised service.

6.4.4 Setting the Basic Data in the Program of the Amplifying and Evaluating Unit MP85

In the program of the amplifying and evaluating unit MP85, there are all basic settings already performed in the production plant. The basic settings of the program are performed so that the unit allows for using all functions in Chapter 7. Unit Functions. The program is password protected so that its breach cannot occur. The safety password is stored on a CD together with the program setting. The CD forms an appendix to the operating manual.

Only a competent person should enter the program using the password – a trained employee, authorised service. The basic settings may be changed only upon agreement with the riveting unit manufacturer.

6.4.5 Setting the Evaluating Criteria of the Riveting Process MP85



These are criterion settings, according to which the riveting process is evaluated and finally marked as good or bad. This setting can only be performed based on the knowledge of connected parts, used rivets, and the technological procedure that will be used during the process. This setting must be specified after the performed tests during regular operation. The process values that are decisive for its quality performance, must be determined by the customer (user). These values may be e.g. the value of the force upon rivet stud tearing off and its tolerance, the value of the rivet stud movement length, for which the rivet body deformation takes place, etc.

 <small>TITGEMEYER Group</small>	OPERATING MANUAL RIVETING UNIT TIOS H350 TIOS H40	Page 27
Prepared by: A. Solfronk		

With regular supply of the unit, the evaluating criterions are not set. It is possible to agree a general preset already in the production plant.

The setting can be performed after connecting the MP85 with a PC. For this action, it is necessary to have the corresponding connecting cable and a control program installed in the PC. The connecting cable and the control program see Chap. 10 Optional Accessories.

The setting of the evaluating criterions may be performed only by a competent person – trained employee, authorised service.

The procedure of setting the evaluating criterions is not the subject of this manual. It requires a separate training and knowledge of the product MP85 by HBM .

6.4.6 Setting the Riveting Process Data Saving

The basic setting during selling from the RIVETEC Company is without data saving. It is possible to preset the data storage already in the production plant upon agreement with the unit manufacturer.

For the possibilities of data storage, see Chap. 7.4 Riveting Process Data Saving.

The setting may be performed after connecting the MP85 with a PC. For this action, it is necessary to have the corresponding connecting cable and the control program installed in the PC. For the connecting cable and the control program see Chap. 10 Optional Accessories.

The data storage setting may only be performed by a competent person – a trained employee, authorised service.

The procedure of data saving setting is not a subject of this manual. It requires a separate training and knowledge of the MP85 product by HBM .

7. UNIT FUNCTIONS

The riveting unit TIOS H350 is equipped with the following main functions:

7.1 Riveting

The riveting function is described in Chapter 8. Operation and control.

7.2 Riveting Process Evaluation

The riveting process is evaluated based on physical quantities (dependence of force on distance) sensed by sensors located in the riveting head. For the actual evaluation, it is necessary to determine the checking windows, through which the curve sensed during the riveting process must pass.

If the curve passes the correct windows, in the correct direction, and in the correct order, the process is evaluated as good (OK). If the curve does not pass some window or not in the correct direction or order, the process is evaluated as bad (NOK).

By the combination of the amount of check windows, their size and location, it is possible to check during the process and evaluate more facts. E.g. the rivet quality – whether it corresponds to the etalon, presence of riveted materials, adherence to basic dimensions of riveted materials and the opening for the rivet, etc.

Process evaluation – visualisation using a diode at the riveting head: **red NOK**

green OK

7.3 Riveting Operation Control

The riveting unit is ready for connection to an external control unit. After connecting, signal exchange is made possible, which will secure control of the riveting process. Individual inputs and outputs are described in Appendix 15.2 Electric Wiring Diagram.

The actual connection is prepared using a connector HARTING – the type is described in the electric wiring diagram.

OUTPUTS – FROM THE INTERNAL SPS INTO THE EXTERNAL SPS

KRB switched on	Signal is active, when KRB safety relay is switched on
NOK signal	Signal is active, when evaluation result is NOK. This signal is switched on for 300ms.
OK signal	Signal is active, when evaluation result is OK. This signal is switched on for 300ms.
Oil temperature - overheating	Signal referencing the oil temperature. This signal is on when oil temperature exceeds allowed value.
Oil level / filter	Signal referencing the oil level and oil filter conditions. This signal is on when some of these situations happens: - oil level is below value 1 - oil level is below value 2 - oil filter is needed to be exchanged
Emergency STOP	Contacts of this signal are used to be connected to safety circuit of upper control system.

INPUTS – FROM THE EXTERNAL SPS INTO THE INTERNAL SPS

Emergency STOP	Contacts of this signal are used to connect the safety circuit of upper control system to safety circuit of KRB.
ON - KRBH	Signal is used to switch on the safety circuit of KRB.
ZERO - KRBH	Signal for setting a zero of sensors
Riveting enabled	Riveting is enabled only when contacts of this signal are in short circuit. This signal allows upper control system to disable riveting after NOK and so.

When using the riveting unit without connection with an external control unit, it is necessary to use the additional unit for controlling the riveting operation (see Chap. 10 Optional Accessories) or turn off the function of the riveting operation control.

This may only be performed by a qualified person – authorised service.

7.4 Riveting Process Data Saving

The data of the riveting processes may be stored in these manners:

A/ Medium type:

- MMC card (about 1000 riveting processes on a 512 MB card) see Optional Accessories
- Into the PC memory

B/ Types of processes to save:

- Only OK processes
- Only NOK processes
- OK and NOK processes

C/ Setting the amount of stored data:

- Without data loss
- With data loss – only the last X (10, 20, 50) processes are saved, old are deleted.

D/ Manner of saving:

- Only curves
- Result saving (also the check window setting is saved)

E/ Saving format:

- ASCII
- QDAS

7.5 Check and Securing Some Technical Parameters of the Unit

The unit is equipped with further auxiliary functions that serve for facilitating maintenance and checking:

- Quantity function: the number of OK, the number of NOK, the number of reset impulses, the number of idle cycles

Everything that is displayed on the control unit panel and individual counters can be reset (see Chap. Operation and Control)

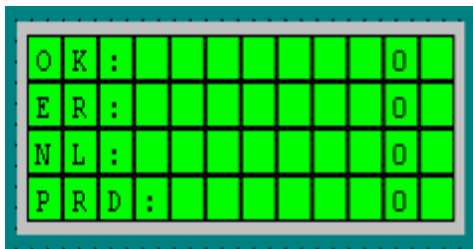

OK riveting counter
NOK riveting counter
Reset impulses counter
Idle cycles counter

- Checking the hydraulic unit temperature: upon exceeding the permitted temperature, the hydraulic unit is turned off – information is displayed on the control unit panel, after temperature drop to the working temperature, it is possible to resume working.
- Check of the hydraulic oil level (two-stage):
 - First stage: the operator is informed at the control unit panel
 - Second stage: until the hydraulic oil is refilled, the hydraulic aggregate is turned off (the information is at the control unit panel)
- Hydraulic oil purity check: in case of filter clogging, the operator is warned by information on the control unit panel, if the filter is not cleaned within 6 hours of operation, the hydraulic aggregate is turned off, namely until the filter is replaced.



ER or No OIL

- Warning - high temperature
- Warning - dearth of oil (1st stage)
- Warning - replace the filter necessary or refill the hydraulic oil

8. OPERATION AND CONTROL

8.1 Warning:

- The riveting head used by you and the rivet may look differently from the used figures.
- When riveting, the tool must be held perpendicular to the riveted material.
- The values of the opening size (D1) and the clamping area (K) must be obtained from the used rivet manufacturer.

8.2 Two-Part Rivet Riveting Procedure

- Put the riveting stud (a) into an opening in the material
- Put the clamping ring (b) on the riveting stud
- Hold the riveting pivot head (a) and pull on the riveting nozzle (Z). Insert the nozzle so that it pushes the clamping ring (b) to the material.
- Press the start button on the riveting head – the riveting operation is performed (the riveting nozzle is pulled on the clamping ring, which pushes it to the material and also deforms it). After tearing off the rivet stud, the hydraulic piston returns into the original position.
- The torn off rivet stud is discharged during the next riveting rearwards from the riveting head.

Attention – it is necessary to use a torn stud catcher.

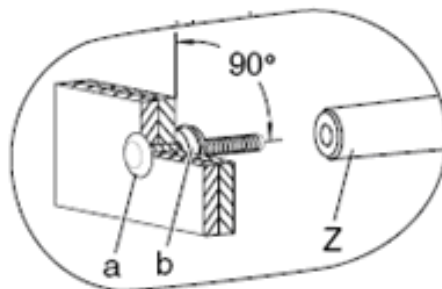
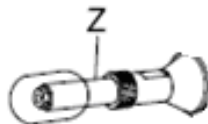
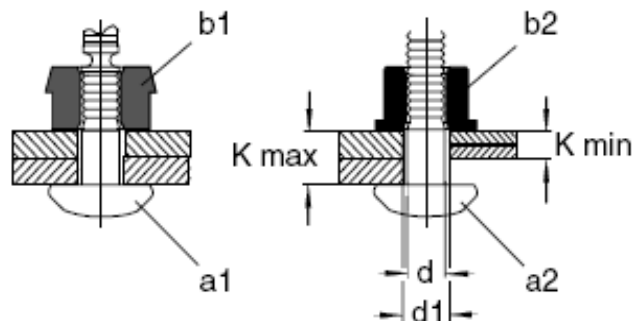

8.3 Procedure of Riveting a Single-Side Ripping Rivet

- Put the ripping rivet (a) into an opening in the material
- Pull on the riveting nozzle on the rivet stud (Z). Insert the nozzle so that it pushes the rivet (a) to the material.
- Push the start button at the riveting head – the riveting operation is performed (the jaws grip the rivet stud and pull it inside the nozzle, which deforms the rivet body and the material is clamped). After breaking the rivet stud, the hydraulic piston returns into the original position.
- The torn off rivet stud falls in the direction of the riveting head tilt.

Attention – it is necessary to use a torn stud catcher.

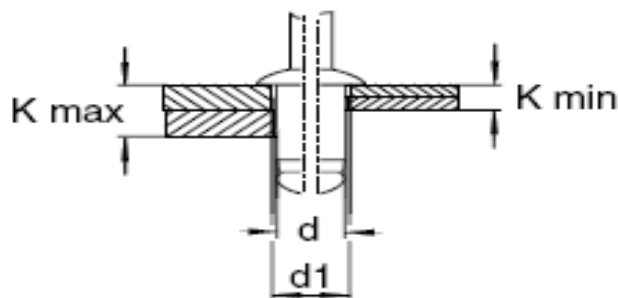
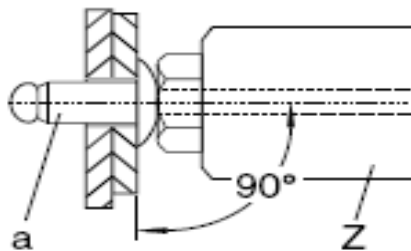
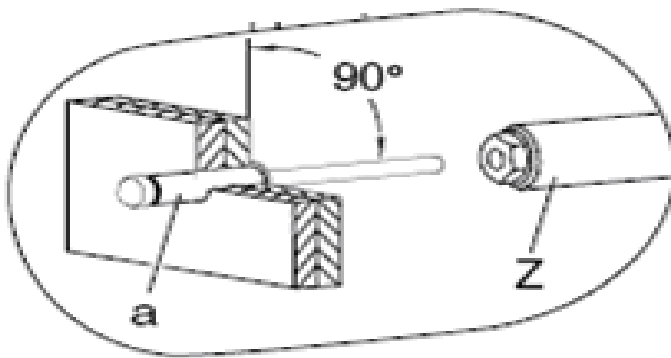
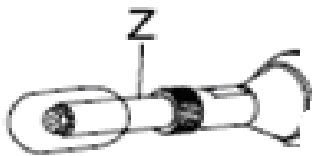

8.4 Process Evaluation

- If the process is evaluated as good, the green diode is lit on the riveting head and 1 pc is added in the control unit into the counter of good processes (OK). In case that the unit is connected with an external control unit, an OK signal is sent to it.
- If the process is evaluated as bad (NOK), the red diode is lit at the riveting head and 1 pc is added to the counter of bad processes (NOK). The riveting head is blocked for further use (unless the control unit program is changed upon the customer's wish). In case that the unit is connected with an external control unit, a NOK signal is sent to it.
- The NOK report must be unblocked, namely using an external control system (if connected) or using an additional unit for riveting operation control (See the Optional Accessories)

8.5 Internal Control System Panel Button Control

The internal unit of the control system (10) is fitted with 8 pcs of buttons that are programmable for the following use:



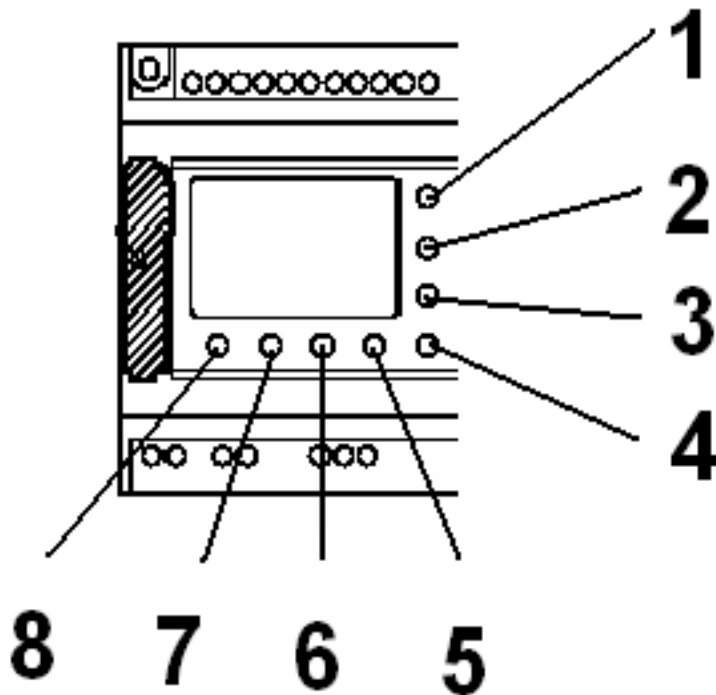

Button 1 - Resetting the amplifying and evaluation unit MP85

Button 2 - Resetting the good cycle counter - OK, the counter of signals for the MP85 used for setting a zero for sensors, the counter of riveting cycles – without rivets

Button 3 - Resetting the counter of bad cycles – NOK

Button 4 - Setting the zero of sensors in the riveting head.

Button 6 and 7 simultaneously – turning on the hydraulics and the command for return of the hydraulic piston in the riveting head into the start position.

ATTENTION – danger of injury by the riveting head (the riveting nozzle must not be dismantled)!

Buttons 5, 6, 7, and 8 - cause the displaying of the SW version.

9. MAINTENANCE



The activities described in this chapter must be performed after turning off the riveting unit and disconnecting the electricity source. In the opposite case, there is a danger of injury.

9.1 Maintenance of the Riveting Head and the Riveting Nozzle

- The riveting head and the riveting nozzle must be kept clean and perform cleaning of the clamping head (4), jaws (3), and the front nozzle (6) every day.
- Every day, before commencing work, it is necessary to check the condition of the front nozzle (6), whether it is not deformed or whether cracks are created. In case that there is a deformation or cracks, it is necessary to replace the nozzle - see 6.2 Assembly .
- Every day before commencing work, it is necessary to check the tightening of the clamping head (4) and the sleeve nut (7). In case of tightening the clamping head, it is necessary to check the X dimension (see Chap. 6.2.1).
- Once a week, check the jaw condition (3), in case of their wear, replace them. See Chap. 6.2.
- Every day, check the nozzle tightening (5).
- Regularly check a possible oil leak at the riveting head
- Once a year, it is necessary to perform setting of the values in the setting chip see chap. 6.4.1.

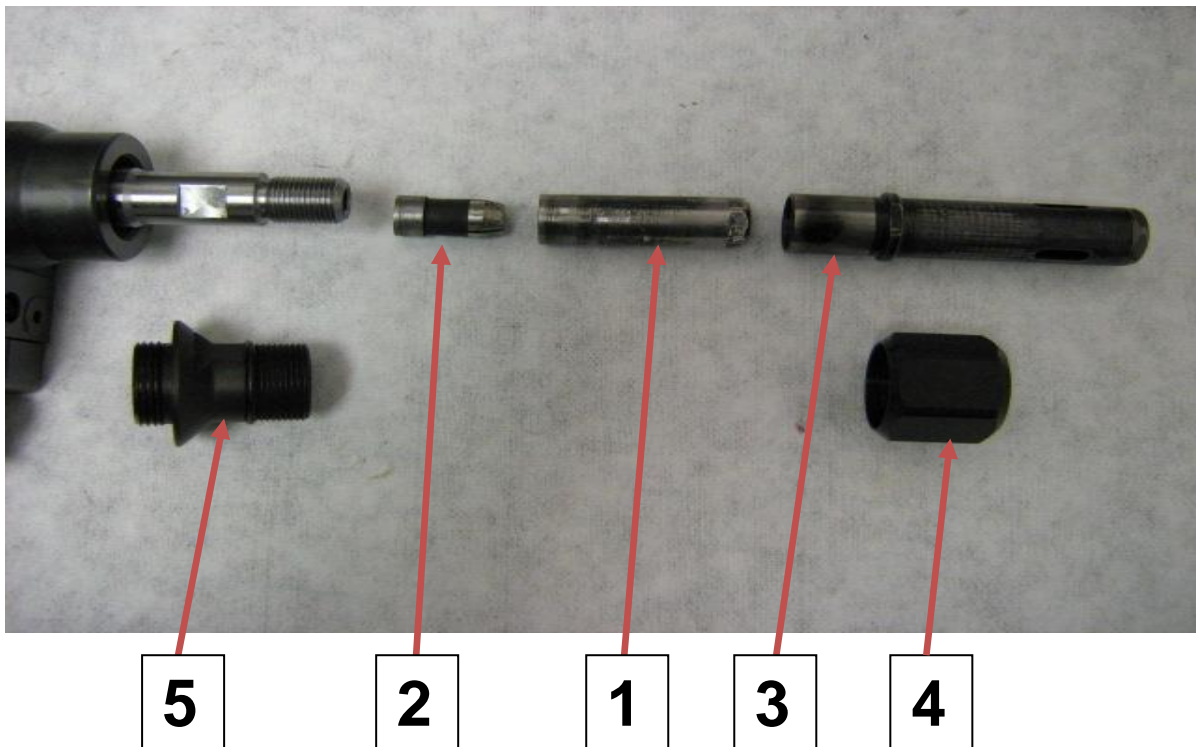

Tightening Torques

POSITION	DESIGNATION	THREAD	TIGHTENING TORQUE (Nm)
5	Nozzle	M 26x1.5	20
4	Sleeve nut	M 24x1,25	8
1	Clamping head	UNEF 9/16"-24	12

9.2 Drive Unit Maintenance

The drive unit is maintenance free, but it is necessary to regularly perform the following checking tasks:

Regular daily checking of reporting on the display of the internal control system:

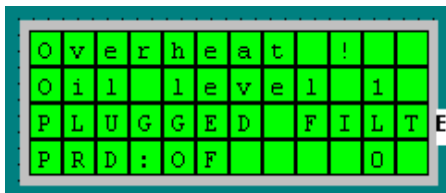

Warning - high temperature

Warning - dearth of oil (1st stage)

Warning - replace the filter necessary
or refill the hydraulic oil

- Message "high temperature of the hydraulic unit" – upon exceeding the permitted temperature, the hydraulic unit is turned off (information is displayed on the control unit panel), upon a temperature drop to the operating temperature, it is possible to resume working.
- Message "lack of oil – first level" – during the nearest shutdown of the unit, it is necessary to refill the hydraulic oil, see 6.1 Installation.
- Message "necessary filter replacement or lack of oil" – it is necessary to check the oil level and refill it (see Chap. 6.1 Installation, if the message lasts, it is necessary to replace or clean the filter of the hydraulic aggregate (this activity may only be performed by trained personnel or an authorised service)).
- Once a week, perform a visual check of the entire hydraulic system, especially secure tightness of individual elements, pipelines, hoses, valves, and the tank.
- Regularly check the connections (once a month) and tighten using the prescribed tightening torque.

Screw Connections and Leak of Hydraulic Elements

The creation of a leak at the contact planes below and between the hydraulic elements,

between flanges, etc. is significantly contributed by insufficiently pre-tensioned screw connections. This condition is a cause of abnormal wear of O-rings and subsequently then the loss of the packing effect. The impression that the screw is tightened enough is usually wrong.

Screws at the hydraulic blocks are well accessible in the vast majority of cases, therefore, it is desirable to tighten them using the prescribed torque using torque wrenches. The tightening torques are stated in the table below.

M4	3 Nm
M5	6 Nm
M6	14 Nm
M8	22 Nm

M10	44 Nm
M12	74 Nm
M16	165 Nm
M20	314 Nm

M24	549 Nm
M30	1020 Nm
M36	1740 Nm
M42	2670 Nm

The values apply to quality screws from materials with mechanical properties 8.8 (screws with a cylindrical head and an internal hexagon). Lower quality screws, mech. properties 5.8 and below, are not recommended for use.

10. OPTIONAL ACCESSORIES

The optional accessories must be ordered separately.

10.1 Torn Stud Discharge

With the unit, it is possible to use 3 options for discharge or catching of torn studs:

- A1 Catching vessel direct including a connecting adapter
- A2 Catching vessel angular including an adapter for connection
- B Catching rubber – it is supplied with the riveting head as standard.
- C Discharge hose – length 2 m

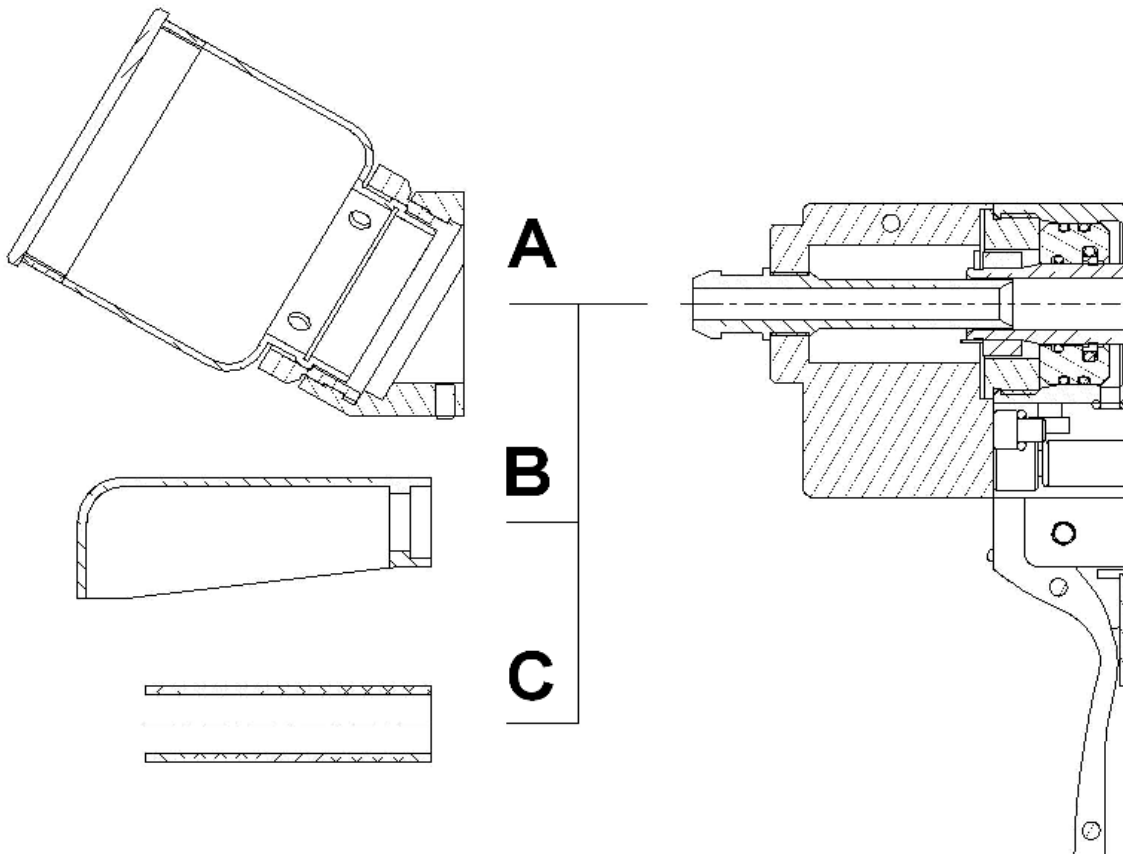

10.2 Set for Connection of a PC with the MP85

- The set serves for the possibility of setting the basic data in the program of the amplifying and evaluating unit MP85, setting the evaluating criterions of the riveting process, setting the riveting process data saving, allows also for direct data saving.
- The set can only be used by a trained person, knowledgeable about the product of the HBM Company, the measuring and amplifying module MP85.
- Set parts: connecting cable, USB adapter, setting SW, SW – USB driver

10.3 Riveting Process Control Box

The box allows for working with the riveting unit in case that the riveting unit is not connected with an external control unit. The box is connected with the riveting unit using the HARTING connector. After connecting, all functions are available as described in Chapter 7.3 Riveting Operation Control.

10.4 MMC Memory Card

The MMC card serves for data storage of the riveting process. The MMC card can be bought in the regular business network.

11. FAILURES AND THEIR REMOVAL

When identifying the failure causes, it is always first necessary to determine, whether the unit function loss is caused by a failure of the electric or hydraulic unit part.

For repairs of failures on hydraulic systems, it is impossible to prepare a unified procedure. However, it is necessary to adhere to all general rules and work procedures:



Before disassembly of any parts of the hydraulic system, it is necessary to make sure that:

- The mechanism, whose hydraulic control will be dismantled, is in a stable position that allows for disconnecting the hydraulics (autonomous unit movement must not occur).
- The hydraulic circuit is disconnected from the pressure source (turned off and depressurised hydraulic drive).
- The hydraulic circuit is disconnected from the electricity source (it is disconnected at the central electric switchboard, the control voltage is turned off at the panel, and the connectors of electric switchboards are dismantled).
- Individual branches of the hydraulic circuit are without pressure (check at the measuring points using a manometer, possibly depressurise).
- During all disassembly works, thoroughly take care about maximum possible cleanliness of the workplace in order to prevent damage of the dismantled parts and introduction of pollutants into the system.
- Replace individual parts only with original spare parts. Use of other parts than original may lead to the unit function loss.
- After completing the assembly, carefully check the setting of the hydraulic elements according to the diagram.
- Before operation, clean individual parts of the hydraulic unit from oil.

Actions that the unit operator may perform – designed using the letter **B**

Other actions may only be performed by a trained qualified person – designated using letter **F**.

FAILURE	POSSIBLE CAUSE	FAILURE REMOVAL
The rivet cannot be torn off, but the hydraulic system works.	Clogged jaws Worn jaws Loose riveting nozzle	(B) Clean the riveting nozzle. (B) Replace the jaws. (B) Perform tightening.
The rivet stud cannot be inserted into the nozzle.	Incorrect riveting nozzle Loose riveting nozzle Clogged opening for stud discharge	(B) Replace the nozzle. (B) Perform tightening. (B) Empty the device for stud discharge.
Hydraulic system leak	Loose connections Damaged packing	(B) Perform tightening (F) Replace – authorised service
Hydraulic piston has not returned into the original position.	Electric failure Low working temperature	(B) Return the piston using buttons to the SPS.
Aggregate does not work.	High working temperature Lack of oil Oil filter clogged	(B) Let the unit cool down. (F) Refill oil. (F) Replace or clean the filter.

12. WEARABLE PARTS

The wearable parts are contained in the riveting nozzle set. These parts must be regularly checked and based on a test and long-term monitoring, determine the rules and dates for their regular replacement.



Appearance of parts and ordering numbers depend on the type of the riveting nozzle and manufacturer.

13. SPARE PARTS

13.1 Spare Parts Storage

- The storage premises must be dry and dust-free with low air humidity.
- Acid or other chemical vapours must not be present. For storage longer than 6 months, it is necessary to properly conserve using conserving oil.
- Spare parts are packaged according to the belonging to functional subgroups.
- Rubber parts must be conserved with glycerine and stored in black polythene bags.

13.2 Exchangeability of Spare Parts

During production, assembly, commissioning, and work of the machine, there is constant modernisation of elements. For these reasons, it is necessary to write the order exactly according to the documentation and check with the actual condition mounted at the unit. Most new elements is exchangeable without modifications, but it is better to have the order assessed by an expert workplace of RIVETEC, spol. s r.o., that is capable of deciding about exchangeability, possibly about necessary modifications to perform.

13.3 Ordering Manner:

- According to the following model:

DESCRIPTION	EXAMPLE		
Serial number	XXXXXXXXXXXXXX		
Unit title	Drive unit / hydraulic aggregate / riveting head		
System title / system drawing number	XXXXXXXXXX	XXXXXXXXXXXXXX	
Part title / part position number / ordering code	Filtering element	x	x
Number of pieces	1		
Complementary data	XXXXXXXXXXXXXX		
Required delivery date	5/2008		

13.4 Piece Lists

13.4.1 Electric Components

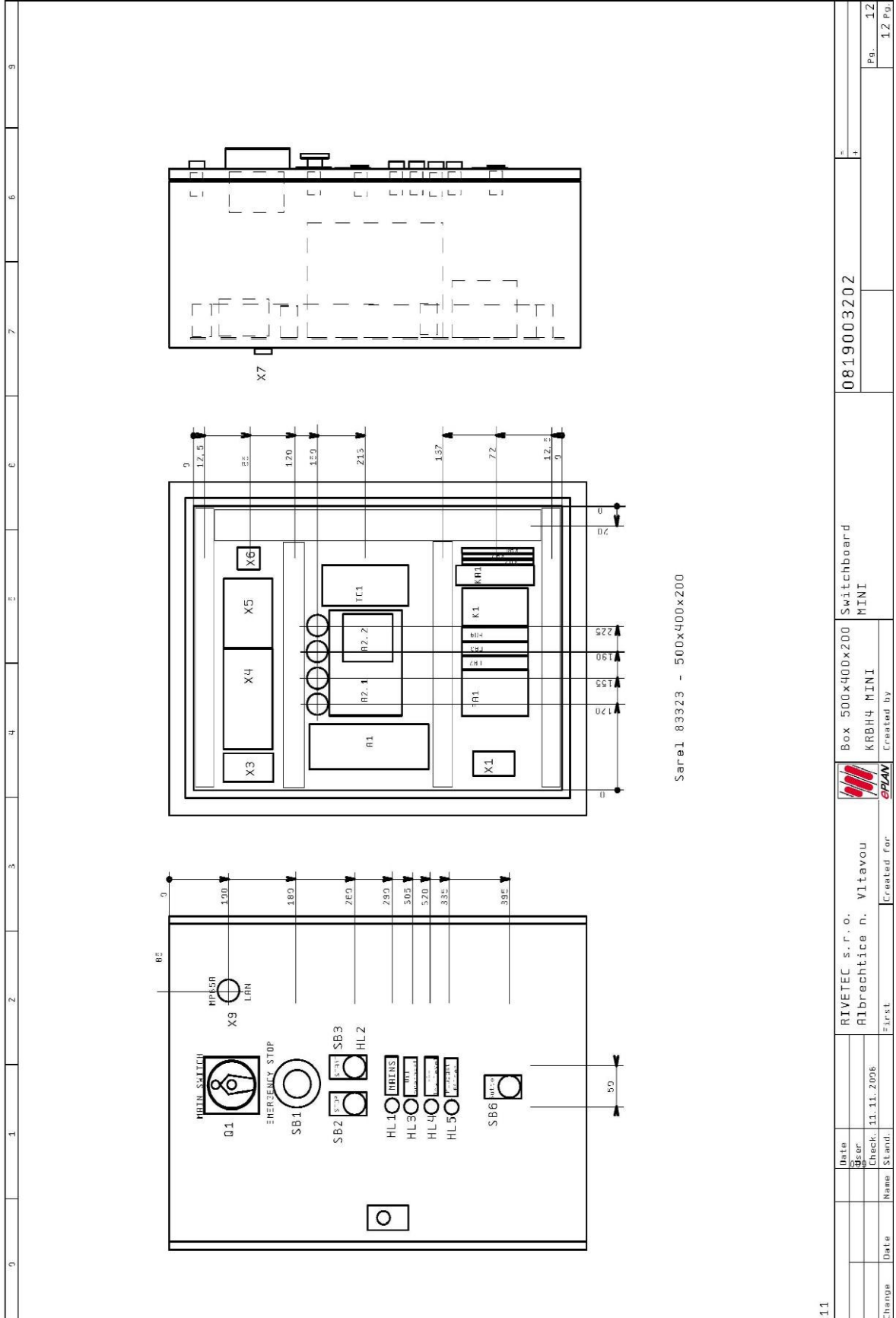

Component designation	Quantity	Designation	Type number	Supplier	Part number
Box	1	Sarel 500 x 400 x 200	83325	Sarel	
Box	1	Schyller 150 x 220 x 75	93244	Schyller	
DI	1	Main switch 250	6H25 10U 2E.E1	Kodjar	
DI	1	Circuitbreaker 3P 50 D	P-7 - D3/3	Moeller	
DI	1	Circuitbreaker 1P 10R D	P-7 - D1/1	Moeller	
DI	2	Circuitbreaker 1P 40 C	PL7 - C4/1 C	Moeller	
DI	1	Power supply 230V/ 24V DC - 4,5A	S6VS-09024	Daron	
DI	1	Two-canal amplifier	MP8EA	Titgemeyer	
DI	1	PLC	RI2-24RR-D	Ritoccont	
DI	1	PLC - expansive plate outputs	43VR	Ritoccont	
DI	1	Contactor 3P 9R - 24VDC	11-009 80	Schneider	
DI	1	Emergency relay	PH02 XE 24V DC	Pliz	
DI	3	SSR relay MRO 5-2-2R	52501	Murr	
DI	1	Plug ICR (3P+4PE) IEC 309	TYPE IV 1653	SEZ	
DI	1	Push button - mushroom actuator with aretation RED	XB2-AS6H45	Schneider	
DI	1	Push button - actuator RED	XB2-RR42	Schneider	
DI	1	Push button - illuminated actuator WHITE	XB2-RA5105	Schneider	
DI	2	Push button - actuator black (part riveting gun)	P-D153K	GM	
DI	1	Push button - selector black	XB2 - RD21 + ZBE - 192	Schneider	
DI	1	Pilot light GREEN	XV2-AR235	Schneider	
DI	3	Pilot light RED	XV2-AR234	Schneider	
DI	1	Diode	1N4007	EM	
DI	1	LED diode two-color (part riveting gun)	L-115 WE3K	EM	
DI	1	Resistor 3K9 0,25	RR 3K9 110-069	EM	
DI	1	Terminal-3pcs grey, 1pc blue, 2pcs green/yellow	280EM1 + 280EM1 + 280EM57	Hago	
DI	1	Terminal-1pc orange, 10pcs grey	2795E4 + 2795E9	Hago	
DI	1	Terminal-1pc orange, 12pcs grey	2705E4 + 2705E9	Hago	
DI	1	Terminal-1pc orange, 13pcs grey	2705E4 + 2705E9	Hago	
DI	1	Connector FN2E2	631E12	EM	
DI	1	Terminal-1pc orange, 20pcs grey	2795E4 + 2795E9	Hago	
DI	1	Socket LAN	2482.720	Rittal	
DI	1	Hydraulic pump	52ER280	Flutec	
DI	1	Block hydraulic valves and baroscops	4HEE6 - 500H980	Hydac	
DI	1	Thermal sensor - oil temperature (part of h. pump)		Hydac	
DI	2	Level sensor - oil level 1. and 2. (part of h. pump)		Hydac	
DI	1	Flow sensor (part of h. pump)		Hydac	
DI	1	Connector R2.5 BRU-Blissol, body R 2.5-17 pol	720000100 R2.5 BRU- Bl/3006110-17p	Lapp Kabel	
DI	1	Connector R2.5 BRU-Blissol, body R 2.5-17 pol 10	72041100 R2.5 BRU- Bl/3006610-17p	Lapp Kabel	
DI	1	Connector R2.5 BRU-Blissol, body R 2.5-17 pol 10	09149050303-1pc, 09149125001-1pc, 09149123101-1pc, 09150705102-12pcs, 19300091541-1pc	Harling	
DI	2	Cover holder	HP-5	Weidmüller	
DI	0,1 m	Cover	ADP-5	Weidmüller	
DI	8	Cable clamps P61E	BS-05	Aspera	
DI	8	Cable clamps P23	BS-32	Aspera	

10

12

Date	30.07.2025	RIVETEC s. r. o.	Box 500x400x200	Bill of materials	0819003202
User	MR	Albrechtice n. Vltavou	KRBH4 MINI		
Check	11.11.2026				
Name	Stand.	First.	Created for	Created by	
Change	Date				
					Pa. 11
					12 P.0.

13.4.2 Hydraulic Aggregate

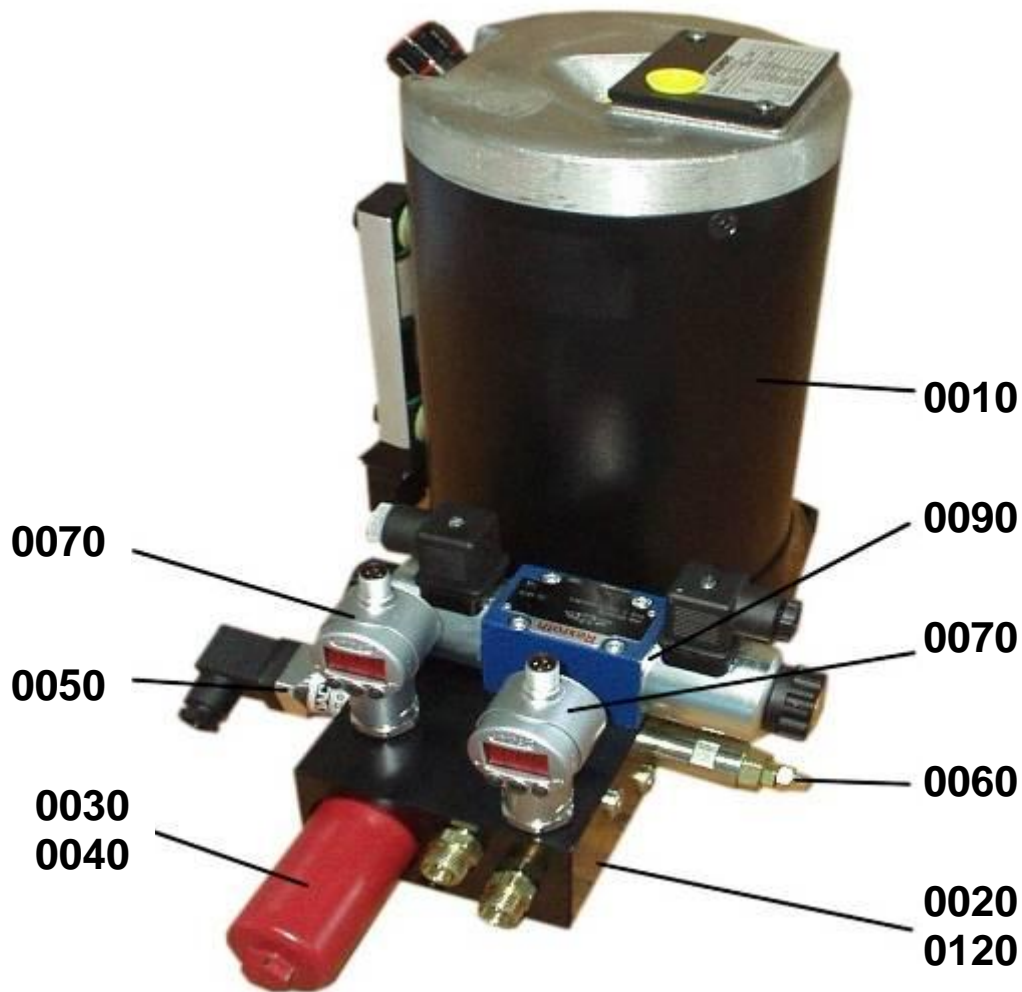

POS.	QUANTITY	UNIT	ORDERING CODE	DESCRIPTION	SUPPLIER
0010	1.00	pcs	3268290	HP200-1,00-05-XTS	HYDAC
0020	1.00	pcs	3289402	BLOCK RIVETEC	HYDAC
0030	1.00	pcs	1250583	MDF 30 SET XX W 1,0	HYDAC
0040	1.00	pcs	1260880	0030 D020 BN3HC	HYDAC
0050	1.00	pcs	311645	VM 2 C.0	HYDAC
0060	1.00	pcs	716024	DB4E-01X630P	HYDAC
0070	2.00	pcs	908167	EDS 3446-10400-000	HYDAC
0090	1.00	pcs	6007617	4WE 6 G6X/EG24N9K4	HYDAC
0120	1.00	pcs	710151	RVE-R1/4-X-0,5	HYDAC
	1.00	pcs	30-1038	Hydraulic quick coupler F	RIVETEC
	1.00	pcs	30-1039	Hydraulic quick coupler M	RIVETEC

13.4.3 Riveting Head

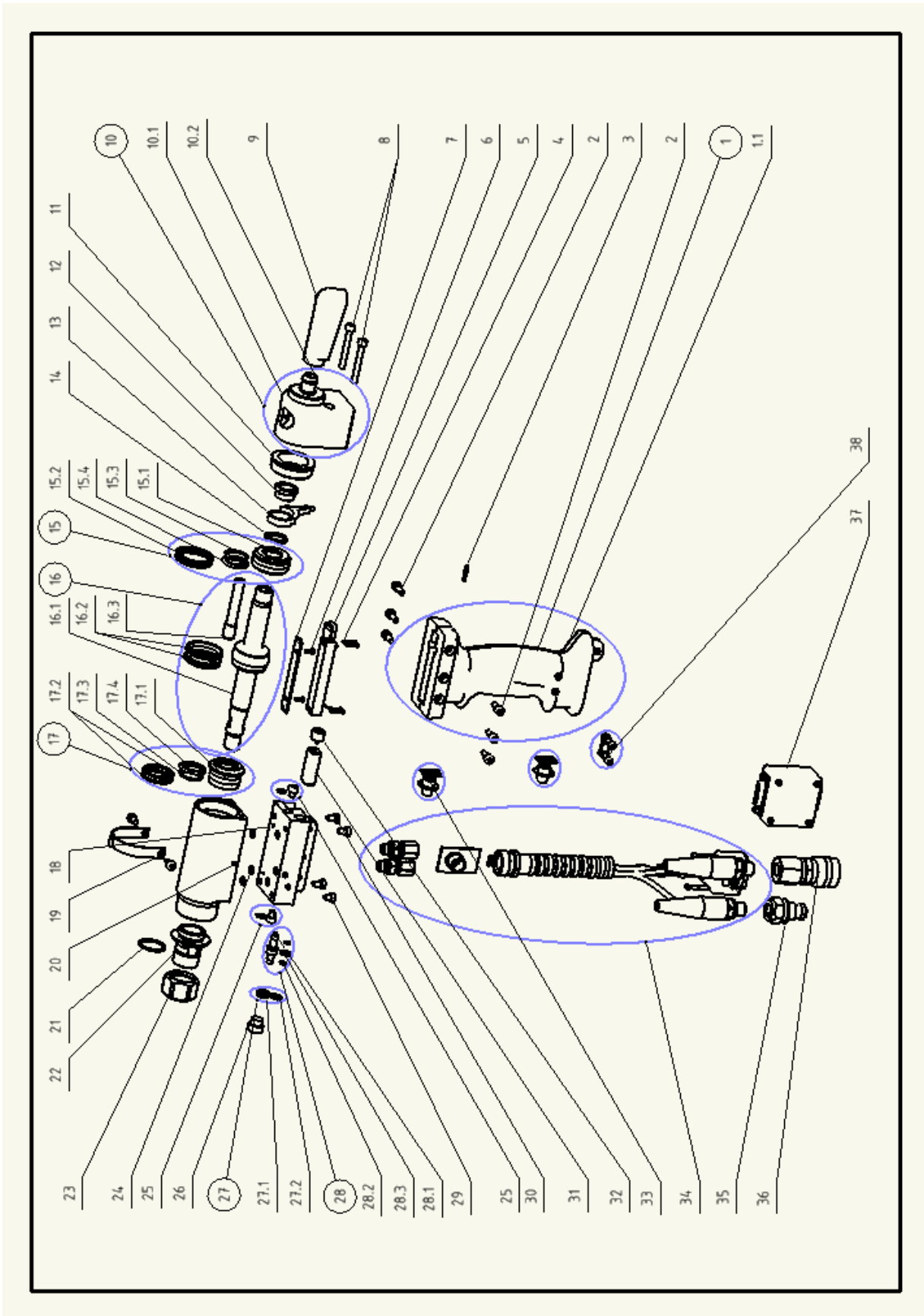

POS.	STOCK No.	VOLUME TITLE	PCS.
1	20-0566	HANDLE	1
1.1	10-1326	HANDLE	1
1.2	30-1067	CROSS RECESSED PAN HEAD TAPPING SCREWS (ISO 7049 - ST4,2x19)	3
2	30-1064	HEXAGON SOCKET HEAD CAP SCREWS (ISO 4762 - M5x12)	6
3	20-0591	DIODE	1
4	30-0912	SLOTTED CHEESE HEAD SCREWS (ISO 1207 - M2x12)	4
5	20-0563	POTENTIOMETER	1
6	30-1068	CROSS RECESSED COUNTERSUNK HEAD SCREWS (ISO 7046 - M3x8)	2
7	10-1319	HOLDER	1
8	30-0742	HEXAGON SOCKET HEAD CAP SCREWS	2
9	30-0320	THORN POT	1
10	20-0618	COVER	1
10.1	10-1400	BACK COVER	1
10.2	10-1402	GUIDE	1
10.3	10-1401	ADAPTER	1
11	10-1405	CAP	1
12	10-1403	NUT	1
13	10-1404	TENON	1
14	10-1407	WASHER	1
15	20-0615	BUSHING GUIDE	2
15.1	10-1406	BUSHING GUIDE	1
15.2	30-1080	O-RING	2
15.3	30-1079	ROD SEALING	1
15.4	30-1081	O-RING	1
16	20-0616	HYDRAULIC PISTON	1
16.1	10-1409	HYDRAULIC PISTON	1
16.2	10-1408	GUIDE	1
16.3	30-1078	PISTON SEALING	1
16.4	30-0530	O-RING	1
17	10-1317	MODULE	1
18	10-1399	BODY	1
19	20-0617	FRONT NOZZLE	1
19.1	10-1410	NOZZLE	1
19.2	30-0214	O-RING	1
20	10-1411	NUT	1
21	30-0193:POLY	O-RING (94° POLYURETAN - 4x2)	3

22	20-0568	SEALING THREAD	2
23	10-1321	NUT	1
24	20-0570	GUIDE	1
24.1	10-1292	GUIDE 2	1
24.2	30-1031	O-RING (DIN 3771 90° - 8x1,5)	1
25	20-0569	COMPENSATOR SET	1
25.1	10-1294	COMPENSATOR	1
25.2	30-1032:POLY	O-RING (94° POLYURETAN - 3x1,5)	2
25.3	30-1033:POLY	O-RING (90° POLYURETAN - 6x2)	1
26	30-0073	HEXAGON SOCKET HEAD CAP SCREWS WITH LOW HEAD (DIN 7984 - M5x6)	1
27	30-1066	HEXAGON SOCKET HEAD CAP SCREWS WITH LOW HEAD (DIN 7984 - M5x8)	3
28	20-0531	TENZIOMETER	1
29	10-1320	NUT	1
30	20-0555	PUSH BUTTON	2
31	20-0564	CABLE HARNESS	1
32	30-1103	CONNECTOR MALE G1/4	1
33	30-1104	CONNECTOR FEMALE G1/4	1
34	20-0538	CALCHIP	1
35	20-0567	HOLDER	1

14. APPENDICES

Hydraulic Diagram

Electric Wiring Diagram

Oil Technical Sheet

Oil Safety Sheet

Protocol – Vibration measurement and evaluation

ES Declaration on conformity

Hydraulic Diagram

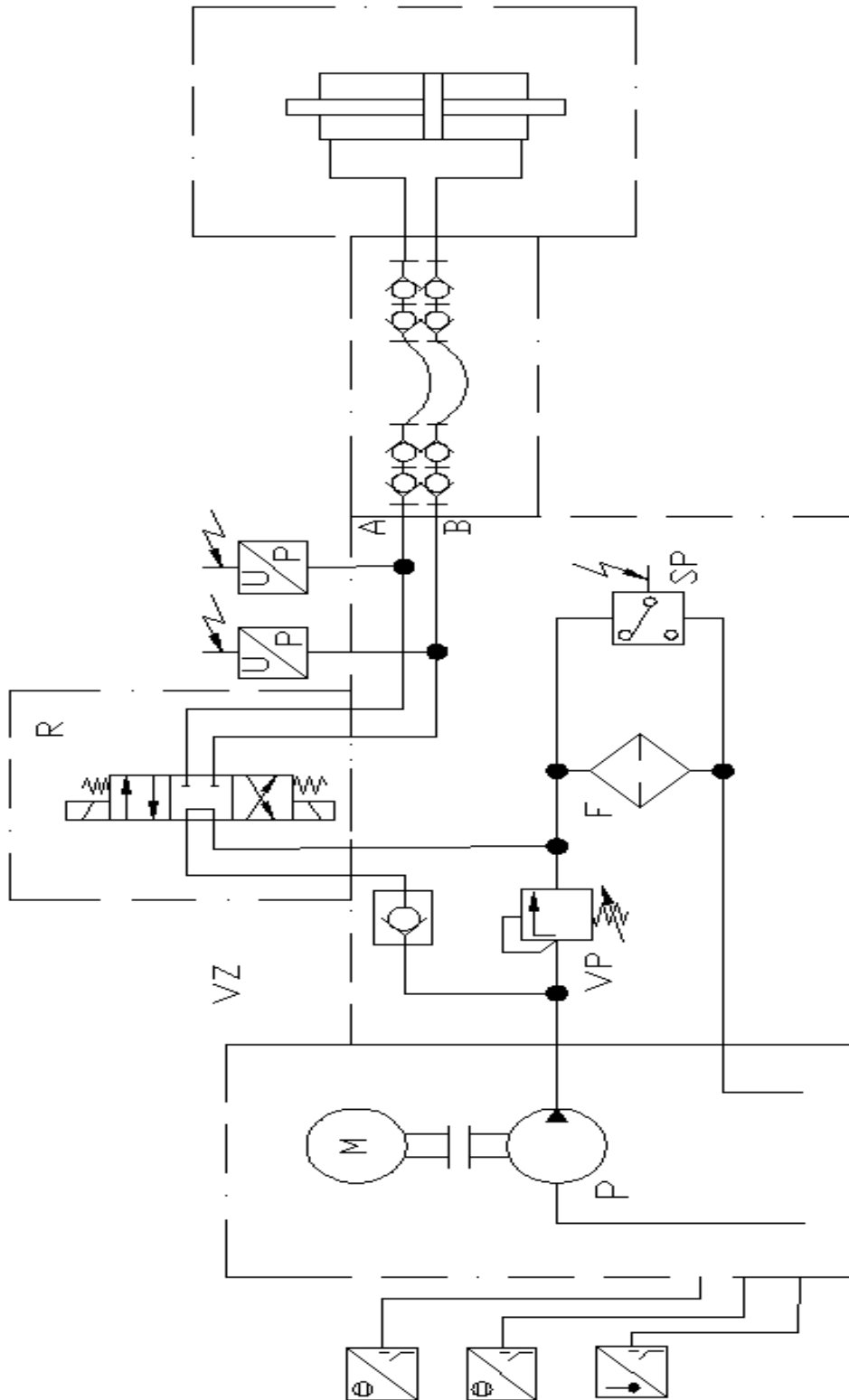

Electric Wiring Diagram

0	1	2	3	4	5	6	7	8	9																																																						
 <p>RIVETEC TITGEMEYER Group</p>																																																															
<p>RIVETEC s.r.o. Albrechtice nad Vltavou 16 398 16 Česká republika</p>																																																															
<table border="1" style="width: 100%; border-collapse: collapse;"> <tr> <td style="width: 30%;">Customer</td> <td style="width: 30%;">: TIOS H350</td> <td style="width: 30%;"></td> </tr> <tr> <td>Plant designation</td> <td>: TIOS H350</td> <td></td> </tr> <tr> <td>Drawing number</td> <td>: 0819008700</td> <td></td> </tr> <tr> <td>Commission</td> <td>: Box 500x400x200</td> <td></td> </tr> <tr> <td>Manufacturer 1</td> <td>: ALBRECHTICE NAD VLTAVOU 16</td> <td>Control panels : IP54/20</td> </tr> <tr> <td>Manufacturer 2</td> <td>: 398 16</td> <td>Incoming supply : 3x400V</td> </tr> <tr> <td>Make</td> <td>: Hydraulic unit</td> <td>Feeder : 16A</td> </tr> <tr> <td>Type</td> <td>: TIOS H350</td> <td>Control voltage : 24VDC</td> </tr> <tr> <td>Installation site</td> <td>:</td> <td>Manufacturing date : 2010</td> </tr> <tr> <td>Particularities</td> <td>:</td> <td></td> </tr> <tr> <td>Special surround.</td> <td>:</td> <td></td> </tr> <tr> <td>Site</td> <td>:</td> <td></td> </tr> <tr> <td>Regulation</td> <td>:</td> <td></td> </tr> <tr> <td>Degree of protect.</td> <td>:</td> <td></td> </tr> <tr> <td>Created on</td> <td>: 27.1.2005</td> <td>Highest Page No. : : 12</td> </tr> <tr> <td>Responsible for project</td> <td>: Holy</td> <td>No. of pages : : 12</td> </tr> <tr> <td>Date changed</td> <td>: 1.3.2010</td> <td></td> </tr> <tr> <td>Editor</td> <td>: holyj</td> <td></td> </tr> </table>										Customer	: TIOS H350		Plant designation	: TIOS H350		Drawing number	: 0819008700		Commission	: Box 500x400x200		Manufacturer 1	: ALBRECHTICE NAD VLTAVOU 16	Control panels : IP54/20	Manufacturer 2	: 398 16	Incoming supply : 3x400V	Make	: Hydraulic unit	Feeder : 16A	Type	: TIOS H350	Control voltage : 24VDC	Installation site	:	Manufacturing date : 2010	Particularities	:		Special surround.	:		Site	:		Regulation	:		Degree of protect.	:		Created on	: 27.1.2005	Highest Page No. : : 12	Responsible for project	: Holy	No. of pages : : 12	Date changed	: 1.3.2010		Editor	: holyj	
Customer	: TIOS H350																																																														
Plant designation	: TIOS H350																																																														
Drawing number	: 0819008700																																																														
Commission	: Box 500x400x200																																																														
Manufacturer 1	: ALBRECHTICE NAD VLTAVOU 16	Control panels : IP54/20																																																													
Manufacturer 2	: 398 16	Incoming supply : 3x400V																																																													
Make	: Hydraulic unit	Feeder : 16A																																																													
Type	: TIOS H350	Control voltage : 24VDC																																																													
Installation site	:	Manufacturing date : 2010																																																													
Particularities	:																																																														
Special surround.	:																																																														
Site	:																																																														
Regulation	:																																																														
Degree of protect.	:																																																														
Created on	: 27.1.2005	Highest Page No. : : 12																																																													
Responsible for project	: Holy	No. of pages : : 12																																																													
Date changed	: 1.3.2010																																																														
Editor	: holyj																																																														
<table border="1" style="width: 100%; border-collapse: collapse;"> <tr> <td style="width: 15%;"></td> <td style="width: 15%;"></td> <td style="width: 15%;"></td> <td style="width: 15%;"></td> <td style="width: 15%;"></td> <td style="width: 15%;"></td> <td style="width: 15%;"></td> <td style="width: 15%;"></td> </tr> <tr> <td>Change</td> <td>Date</td> <td>Name</td> <td>Stand.</td> <td>Check.</td> <td>User</td> <td>Date</td> <td>Ek</td> </tr> <tr> <td></td> <td></td> <td></td> <td></td> <td>1.3.2010</td> <td>EK</td> <td></td> <td></td> </tr> </table>																		Change	Date	Name	Stand.	Check.	User	Date	Ek					1.3.2010	EK																																
Change	Date	Name	Stand.	Check.	User	Date	Ek																																																								
				1.3.2010	EK																																																										
<table border="1" style="width: 100%; border-collapse: collapse;"> <tr> <td style="width: 30%;"></td> <td style="width: 30%;"></td> <td style="width: 30%;"></td> </tr> <tr> <td>Title page</td> <td>0819008700</td> <td>Box 500x400x200 TIOS H350 Created by</td> </tr> <tr> <td>ESSECODE</td> <td></td> <td></td> </tr> </table>													Title page	0819008700	Box 500x400x200 TIOS H350 Created by	ESSECODE																																															
Title page	0819008700	Box 500x400x200 TIOS H350 Created by																																																													
ESSECODE																																																															
<table border="1" style="width: 100%; border-collapse: collapse;"> <tr> <td style="width: 10%;"></td> <td style="width: 10%;"></td> <td style="width: 10%;"></td> <td style="width: 10%;"></td> <td style="width: 10%;"></td> <td style="width: 10%;"></td> <td style="width: 10%;"></td> <td style="width: 10%;"></td> <td style="width: 10%;"></td> <td style="width: 10%;"></td> </tr> <tr> <td>ESSECODE</td> <td></td> <td></td> <td></td> <td></td> <td></td> <td></td> <td></td> <td></td> <td></td> </tr> </table>																				ESSECODE																																											
ESSECODE																																																															

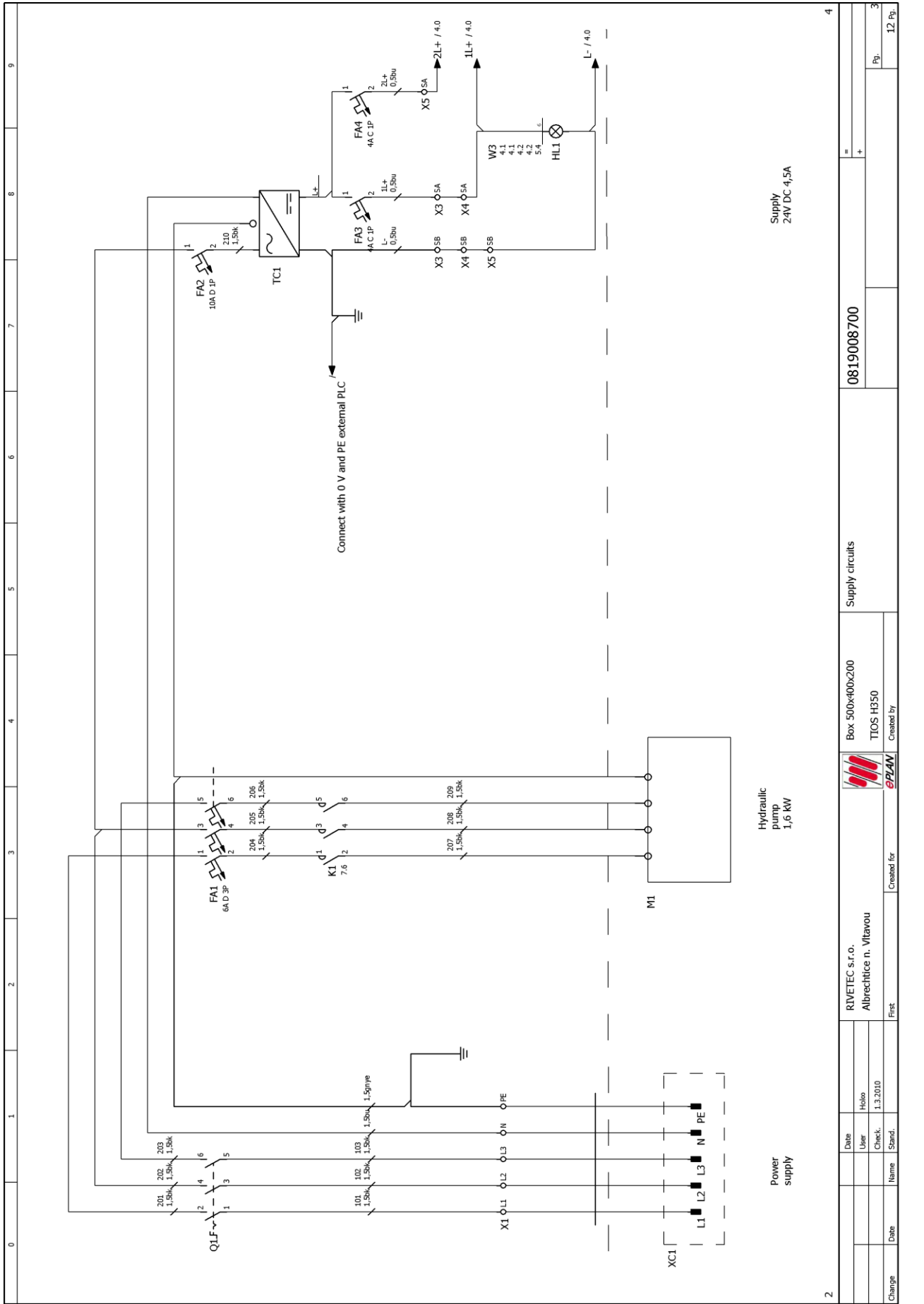

0819008700

Supply circuits

Box 500x400x200
TIOS H350
Created by



RIVETEC s.r.o.
Albrechtice n. Vltavou

First

Date
User
Holo

Check
1.3.2010

Name
Stand.

Change

Date

Pp. 3

12 Pp.

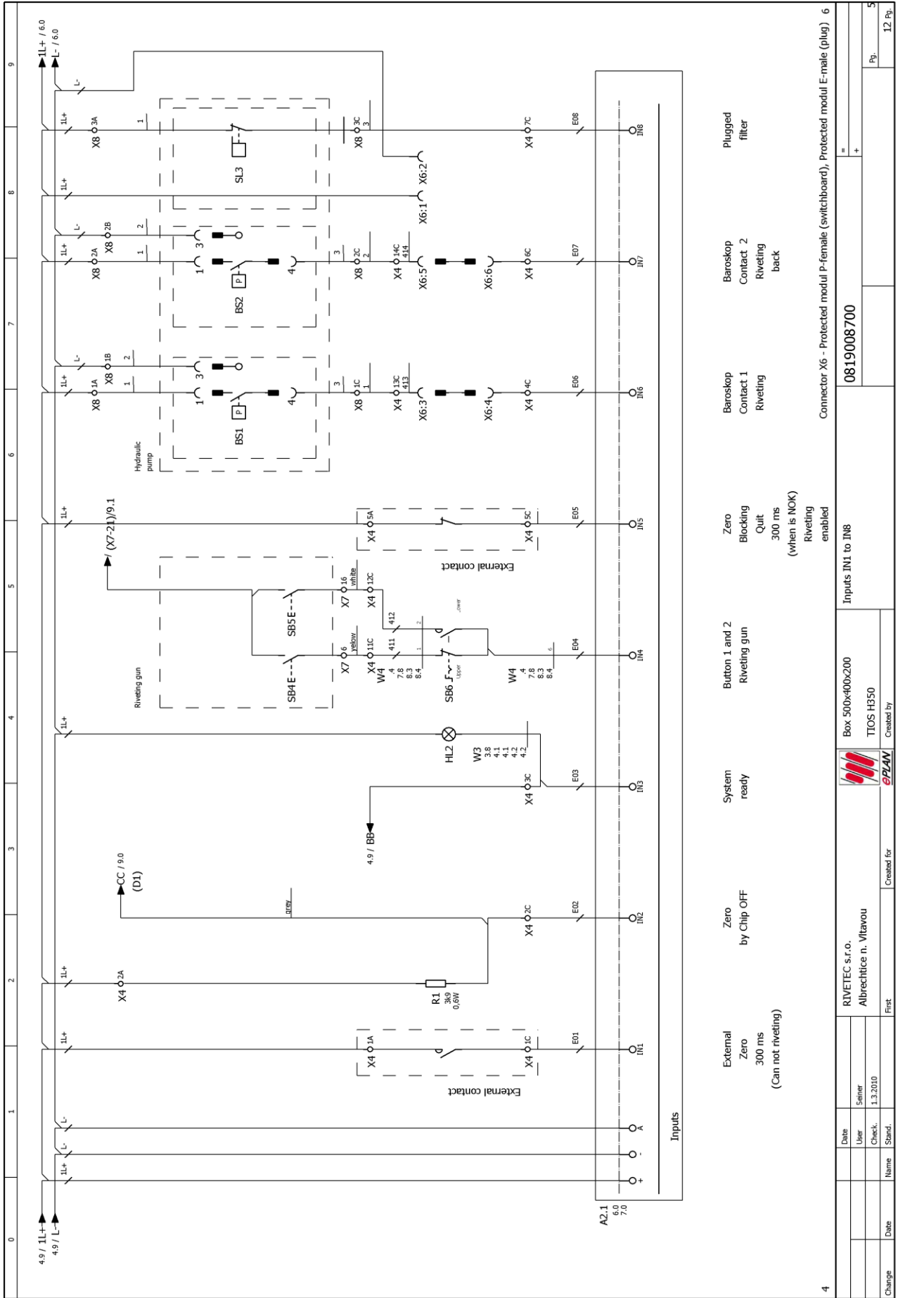

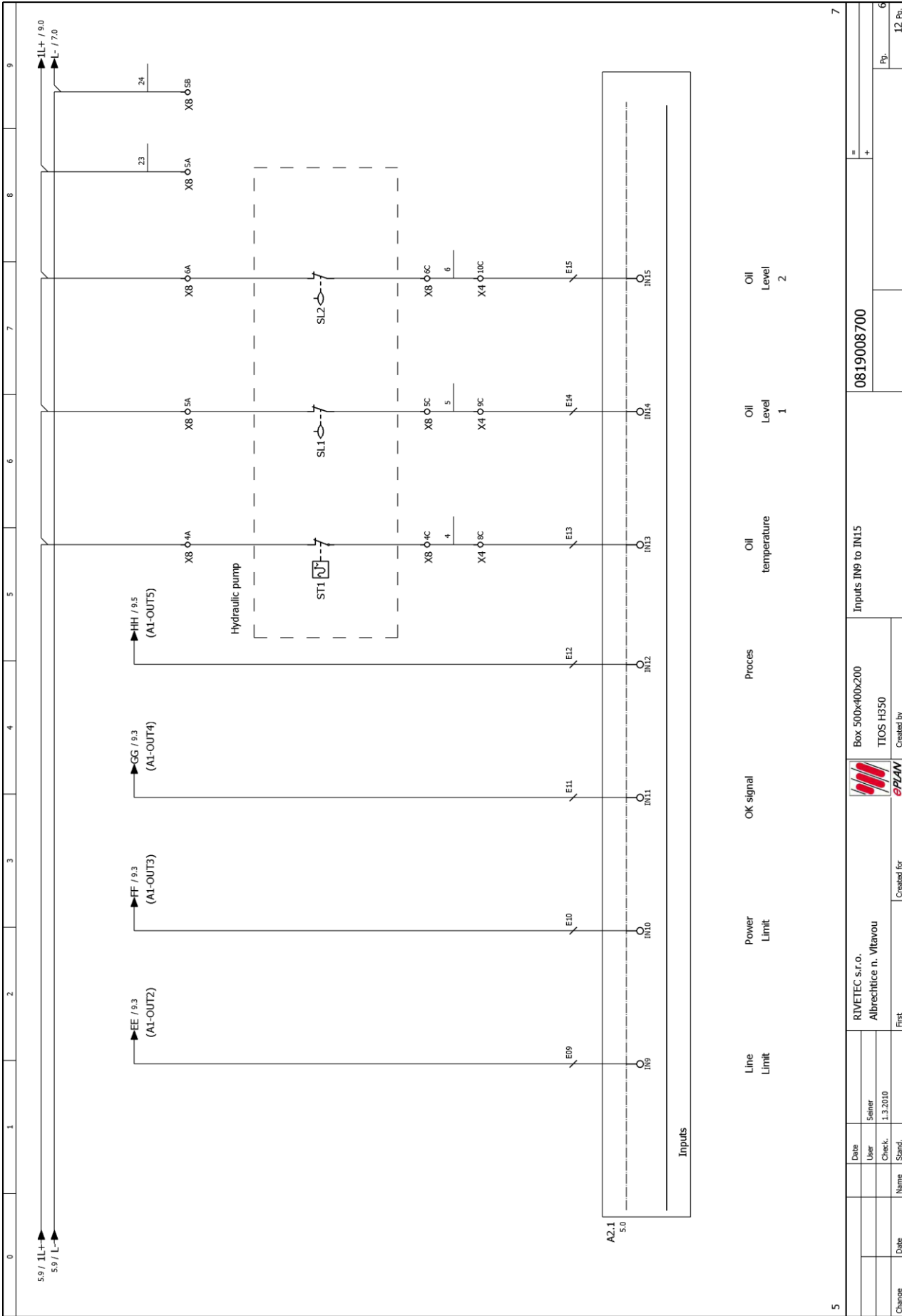

5	A2.1 5.0		Inputs	Line Limit	Power Limit	OK signal	Process	Oil temperature	Oil Level 1	Oil Level 2	7
Change	Date	Name	First	Created for		Created by		Inputs IN9 to IN15		0819008700	12 Pg.
	Date	User	Seiner	RIVETEC s.r.o.		Box 500x400x200		TIOS H350			6
	Check.	Stand.	1.3.2010	Albrechtlice n. Vitavou		EPLAN					

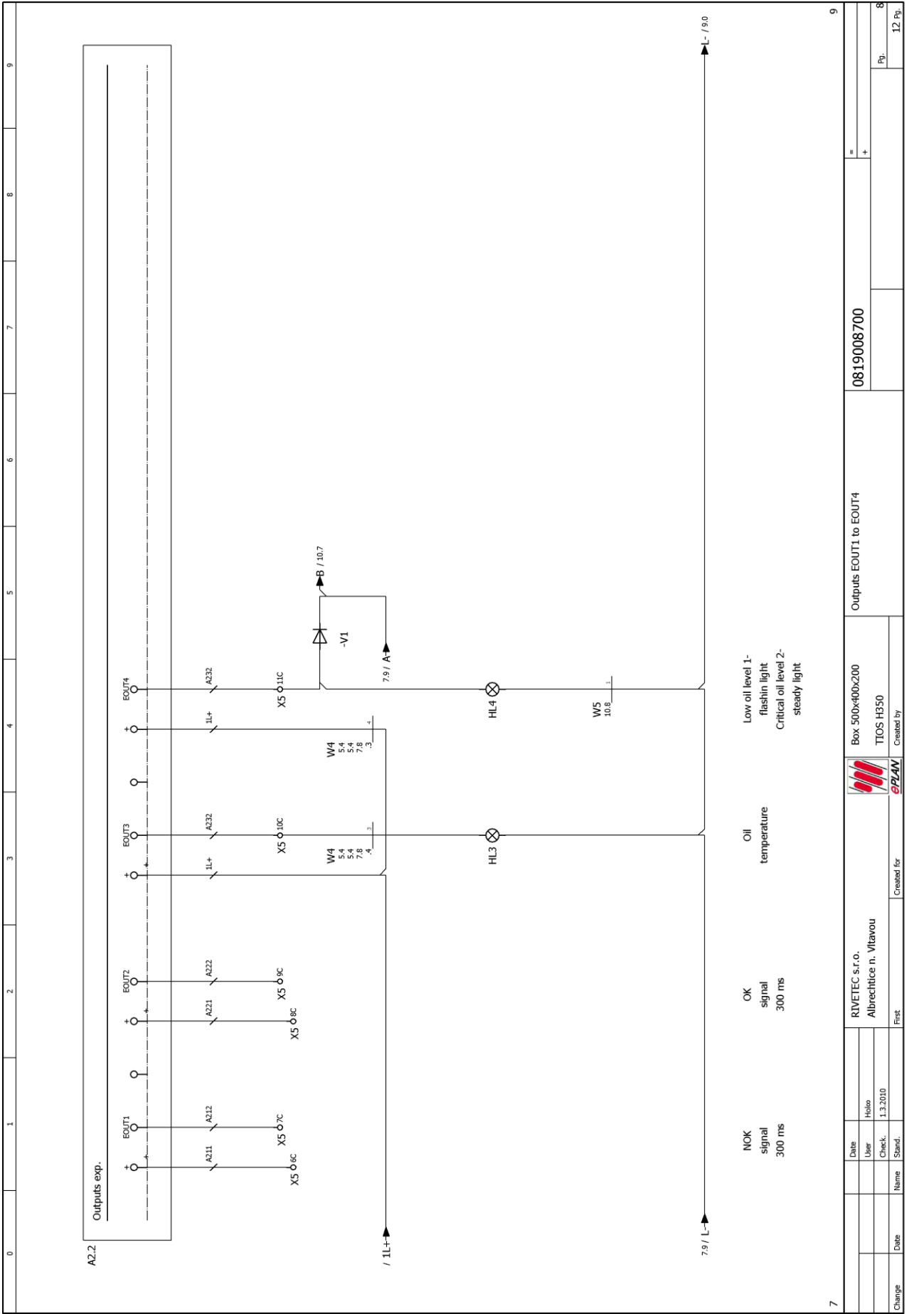

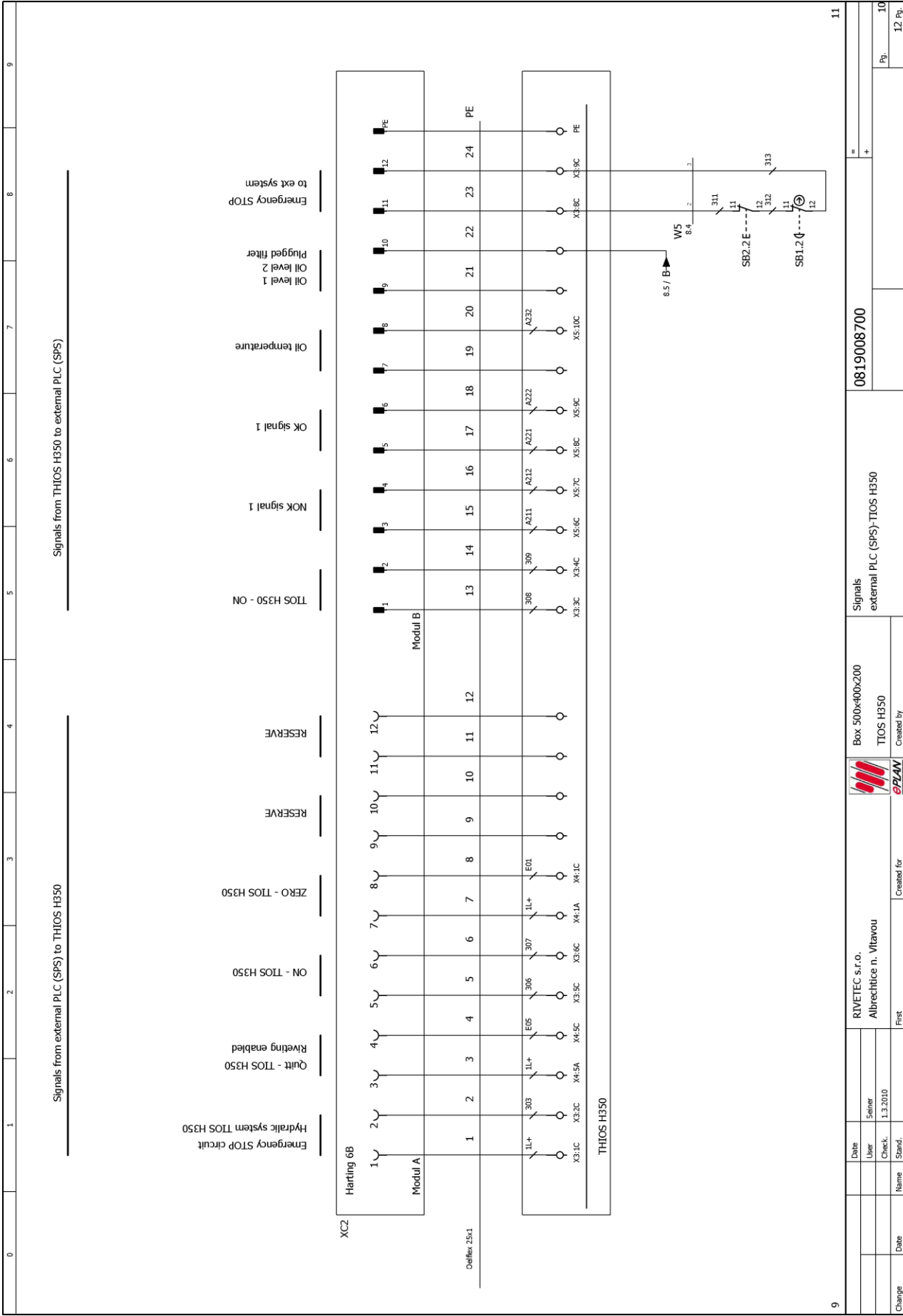

Bill of materials		ES0004E													
Component designation	Quantity	Description	Type number	Supplier	Part number	0	1	2	3	4	5	6	7	8	9
Box	1	Schneider 500 x 400 x 200	NS153D42DP	Schneider											
Box	1	Schyller 150 x 220 x 75	93244	Schyller											
Q1	1	Main switch 25A	GN25.100.25.51	Kon'lar											
FA1	1	Circuitbreaker 3P 6A D	PL7 - D613	Moeller											
FA2	1	Circuitbreaker 1P 10A D	PL7 - D10/1	Moeller											
FA3, FA4	2	Circuitbreaker 1P 4A C	PL7 - C4/1 DC	Moeller											
TC1	1	Power supply 230V/ 24V DC - 5A Eco rail	85303	Murr											
A1	1	Two-canal amplifier	MPS5A	Titgemeyer											
A2.1	1	PLC	Al2-2MR-D	Autocont											
A2.2	1	PLC - expansive plate outputs	4ER	Autocont											
K1	1	Contactor 3P 9A - 24VDC	LC1-D09 BD	Schneider											
KA1	1	Emergency relay	RNO2 X2 24V DC	Ritz											
KA2, KA3, KA4	3	SSR relay MICRO 6.2 2A	53501	Murr											
XC1	1	Plug 16A (3P+N+PE) IEC 309	TYPE IV 16S3	SEZ											
SB1	1	Push button - mushroom actuator with aeration RED	XBS-AS8H45	Schneider											
SB2	1	Push button - actuator RED	XBS-AM42	Schneider											
SB3, HL2	1	Push button - illuminated actuator WHITE	XBS-AM3185	Schneider											
SB4, SB5	2	Push button - actuator black (part riveting gun)	P-OT65W	GH											
SB6	1	Push button - selector black	XBS - AD21 + ZBE - 102	Schneider											
HL1	1	Pick light GREEN	XVL-A233	Schneider											
HL3, HL4, HL5	3	Pick light RED	XVL-A234	Schneider											
D1	1	Diode	1M407	GH											
D2, D3	1	LED (diode) blue/amber (part riveting gun)	L-115 WEGW	GH											
R1	1	Resistor 309 0.6W	RR 309 110-089	GH											
X1	1	Terminal-3pcs grey, 1pc blue, 6pcs green/yellow	280641 + 280651 + 280637	Wago											
X3	1	Terminal-1pc orange, 10pcs grey	270564 + 270560	Wago											
X4	1	Terminal-1pc orange, 17pcs grey	270564 + 270560	Wago											
X5	1	Terminal-1pc orange, 13pcs grey	270564 + 270560	Wago											
X7	1	Connector CAN16Z	801E112	GH											
X8	1	Terminal-1pc orange, 20pcs grey	270564 + 270560	Wago											
X9	1	Socket LAN	2482.720	Rittal											
M1	1	Hydraulic pump	3368290	Fluotec											
Y1, Y2, BS1, BS2	1	Block hydraulic valves and lancecops	4WEEG - 6004980	Hydac											
ST1	1	Thermal sensor - oil temperature (part of h. pump)		Hydac											
SL1, SL2	2	Level sensor - oil level 1 and 2 (part of h. pump)		Hydac											
SL3	1	Flow sensor (part of h. pump)		Hydac											
X6	1	Connector R2.5 BAUF-A1-Hsol. body R.2.5-17 pol	72090000 R2.5 BAUF-A1+73006110-17p	Lapp Kabel											
Opposite ps X6	1	Connector R2.5 BAUF-DBHsol. body R.2.5-17 2088	72061100 R2.5 BAUF-DB6+73006600-17p	Lapp Kabel											
XC2	1	Connector Harting 08		Harting											
	2	Cover holder	HP3	Wedmüller											
	0,1 m	Cover	ADP3	Wedmüller											
	6	Cable clamps PG16	BS-05	Aspera											
	8	Cable clamps PG9	BS-02	Aspera											

10

12

Change	Date	Name	Stand.	Created for	Created by	Bill of materials	0819008700	11	12
	30.7.2003					Box 500x400x200			
	MAR					TIOS H350			
	1.3.2010								

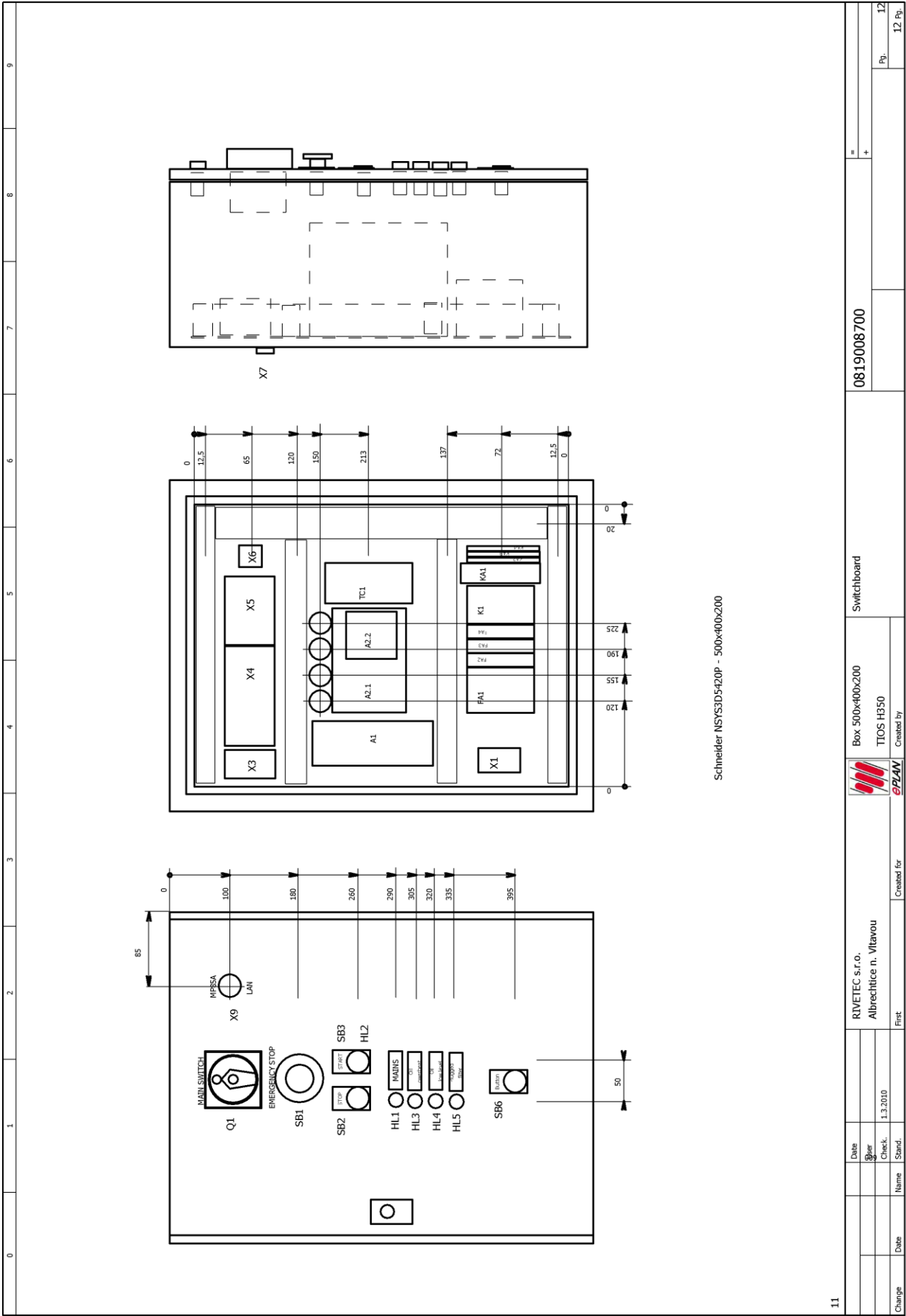

Schneider NSYS3D5420P - 500x400x200

11

Change	Date	Name	Stand.	1.3.2010	First	RIVETEC s.r.o. Albrechtice n. Vitavou	Created for	Box 500x400x200 TIOS H350	Switchboard	0819008700	Pj.	12	12 Pj.
--------	------	------	--------	----------	-------	--	-------------	------------------------------	-------------	------------	-----	----	--------

Oil Technical Sheet

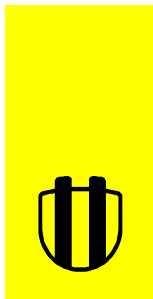

Slovnaft

INDUSTRIAL OILS

Madit OH-HM 32 HYDRAULIC OIL

Technical Information Bill

Description:

Hydraulic oil **Madit OH - HM 32** is solvent-refined and hydrotreated mineral oil with additives for improving oxidation stability, anticorrosion and antiwear properties, and antifoaming additives.

Use:

The oil **Madit OH - HM 32** is designed for hydrostatic mechanisms with high mechanical and thermal load; for stationary and mobile machines, working in the unprotected environment.

They are all-season oils and are compatible with most oils of other producers.
 Approved by ZŤS, Dubnica nad Váhom, Slovakia.

Specifications:

Viscosity class:	ISO VG 32
Performance profile:	ISO-L-HM ISO 11158 HM HLP (DIN 51 524-2) HM (AFNOR NF E 48-603) Cincinnati Lamb P-68 Bosch Rexroth RE 90220

Physical & Chemical Properties:

Density at 15°C, kg/ m ³	informative	872
Kinematic viscosity at 40°C, mm ² /s		28,8 - 35,2
Kinematic viscosity at 100°C, mm ² /s	minimum	5
Dynamic viscosity at -20°C (CCS), Pa.s	maximum	2,5
Viscosity index	minimum	95
Open cup flash point according to Cleveland, °C	minimum	180
Pour point, °C	maximum	-33
Deemulsification characteristic at 54°C, min.	maximum	40

Packaging:

Madit OH-HM 32 is supplied in 60 and 200 litres metal painted barrels, for wholesale in returnable containers, in tank cars and in railway tank cars.

Storage Conditions:

Madit OH-HM 32 should be stored in closed original containers on the places protected against weather effect, strong sunlight and heating surfaces at the temperature to +40°C. Storage time at meeting above mentioned conditions is 3 years.

Manipulation:

Respect the safety principles at work with oil products.
For more information ask for the product's Safety Data Sheet.

Contact place for marketing information:

Slovnaft a.s., Technický servis mazív, Vlčie hrdlo, 824 12 Bratislava 23, Slovakia
Tel.: +421/2/5859 7646; 5859 7263; 5859 7647; 5859 7264; 5859 7399
Fax: +421/2/4524 6829
madit@slovnaft.sk, www.madit.sk

The data conform with the present technical state, we reserve the right of changes.

January 2006

Oil Safety Sheet

1.1.1.1.1

**MATERIAL SAFETY
DATA SHEET****MOL-LUB
Ltd.****(91/155 EC)**Trade name: **Madit OH-HM 32 hydraulic oil**

Version: 3 Latest revision: 12. 09. 2006 Date of issue: 04. 12. 2003 Page: 1/(7)

14.1.1.1.1.2

1.14.1.1.1.1.3 *Identification of the substance / preparation and company*

Product name:

14.1.1.2 Madit OH-HM 32Product type / recommended uses:
preparation / hydraulic oil

Manufacturer / Supplier identification:

MOL-LUB Lubricant Production Trade and Service Limited Liability Company
H-2931 Almásfüzitő, Fő u. 21., Hungary**14.1.1.2.1 Phone / Fax: (+36-34) 526-330 / (+36-34) 526-391****14.1.1.2.2 For more information contact:**

MSDS:

MOL-LUB Lubricant Production Trade and Service Limited Liability Company
Customer Service Center
H-2931 Almásfüzitő, Fő u. 21., Hungary**14.1.1.2.3 Phone / Fax: (+36-80) 201-296 / (+36-34) 348-010**

Technical information:

MOL-LUB Ltd. Product Development and Technical Service
H-1117 Budapest, Október huszonharmadika u. 18., Hungary**15. Phone/Fax: (+36 - 80) 201-296 or (+36 - 1) 464-0236 / (+36 - 1) 464-0304****15.1 Emergency phone number: (+36) 34 526-210 or (+36) 34 526-144****15.2 Health Toxicological Information Service (ETTSZ 1096 Budapest, Nagyváradi tér 2.)****15.3 Tel.:(+36 - 1) 476-6464, or (+36 - 80) 201-199**

15.4

2. Composition / information on ingredients

Chemical description: Refined mineral oil containing additives (antioxidant, corrosion-inhibitor, antiwear, viscosity modifier and pour point depressant).

Ingredients / Hazardous components:

15.4.1 <u>Name</u>	15.4.1.1 <u>CAS/EINECS number</u>	Hazard symbol	Risk phrase	Conc. %(m/m)
Base oil	101316-70-5/309-875-6	-	-	} 98 – 99.5
	101316-72-7/309-877-7	-	-	
Zinc alkyl dithiophosphate	confidential	Xi	R 36/38	max. 0.5

The full text of each relevant R phrase see in Section 16.

3. Hazards identification

Human health hazards: -

Note: Prolonged and/or repeated contact may cause irritation depending on individual sensitivity (see also Protective unit).

Safety hazards: -

Environmental hazards: -

4. First aid measures

General information: Never give anything by mouth to an unconscious person, or never induce vomiting.

Inhalation: Remove the affected person to fresh air. If rapid recovery does not occur, obtain medical attention.

Skin contact: Wash skin with large amounts of water, use soap. If irritation persists, obtain medical attention.

Eye contact: Flush eyes with plenty of water for 10-15 minutes. Obtain medical attention.

Ingestion: If swallowed, give water, **do not** induce vomiting. Get medical attention.

Note to physician:

5. Fire-fighting measures

Fire hazards:

Moderately hazardous (see also Section 9 - flash point).

Suitable extinguishing media:

Foam, carbon dioxide, dry chemical powder.

Unsuitable extinguishing media:
Water jet.

Hazardous decomposition products:

On burning, phosphor oxides, sulphur oxides, at elevated temperature hydrogen sulphide can be formed.

In case of incomplete combustion, carbon monoxide, various hydrocarbons and soot can be formed.

Special protective unit:

-

Further information:

-

6. Accidental release measures

Personal precautions:

See Section 8.

Environmental precautions:

Prevent spills from entering into natural water, soil and drains by containing the liquid. Notify relevant authority.

Clean-up procedures / recovery

On soil: Contain spilled liquid with sand, earth or other suitable absorbents. Recover free liquid by pumping. Dispose of according to local regulations.

On water: Confine the spillage. Remove from surface by skimming or suitable absorbents. Notify local authorities according to regulations.

7. Handling and storage

Handling:

Keep away from radiant heat and open flame.

Keep general measures applied for normal operations with lubricants. No special requirements.

When using do not eat, drink or smoke. Avoid splashing the product.

Storage:

Store in dry, well ventilated place in tightly closed containers.

Keep away from radiant heat, open flame and strong oxidizing agents.

Storage temperature: max. 40°C.

8. Exposure controls / personal protection

Engineering control measures:

Not required.

Exposure limits:

Mineral oil mist: TWA: **5 mg/m³**; STEL: 10 mg/m³, for oil mist, vapour excluded (ACGIH).

Personal protection:

Respiratory protection: Breathing apparatus not required.
Hand protection: Oil-proof gloves (e.g. – PVC, nitrile).
Eye protection: Protective goggles not required.
Skin protection: Protective clothing.
Other special:

General protective measures / hygiene:

Avoid contact with skin and eyes. Avoid prolonged breathing of oil vapours or mists.
Ensure washing facilities after working hours and before breaks. Take off contaminated or oil-soaked clothing, wash with warm water and soap.

9. Physical and chemical properties

Appearance:

Physical state:	liquid, viscous
Colour:	yellow to brownish red
Odour:	characteristic
Change in physical state:	
Pour point (ISO 3016):	typ. -36°C
Boiling point:	
Flash point (COC) (EN ISO 2592):	typ. 210°C
Ignition point (EN ISO 2592):	
Autoignition temperature:	not available
Explosive properties:	not explosive
Oxidizing properties:	
Vapour pressure at 20°C:	negligible
Density at 20°C (EN ISO 12185):	typ. 0.876 g/cm ³
Solubility in water:	practically insoluble in water
Solubility in other solvents:	gasoline, kerosene, toluene, etc.
n-Octanol/water partition coefficient:	not available
Others:	
Heating value:	inf. 42 000 kJ/kg
Kinematic viscosity (EN ISO 3104)	
at 40°C, mm ² /s:	typ. 32.4 mm ² /s
at 100 °C, mm ² /s:	typ. 5.5 mm ² /s
pH:	not applicable

10. Stability and reactivity

Stability:	No decomposition if stored and handled properly.
Conditions to avoid:	Direct heat or ignition sources.
Materials to avoid:	Strong oxidizing agents.
Hazardous decomposition products:	On burning, phosphor oxides, sulphur oxides, at elevated temperature hydrogen sulphide can be formed. In case of incomplete combustion, carbon monoxide, various hydrocarbons and soot can be formed.

Under normal conditions no dangerous decomposition products are formed.

Notes:

11. Toxicological information

Acute toxicity:

Oral (OECD 401):	LD ₅₀ (rat)	> 2000 mg/kg	(based on components)
Dermal (OECD 402):	LD ₅₀ (rabbit)	> 2000 mg/kg	(based on components)

Irritation, skin sensitization:

Skin:	not irritant (based on components)
Eye:	not irritant (based on components).
Note:	Prolonged and/or repeated contact may cause irritation depending on individual sensitivity.
Sensitization:	not sensitising (based on components)

Chronic toxicity: not known

Other information, specific effects:

The product does not contain PCBs, PCTs, and other chlorine compounds, and heavy metals, barium compounds.

The base oil(s) contain(s) less than 3% DMSO extract (IP 346), therefore not classified as carcinogenic material according to 67/548/EEC NOTE L.

Carcinogen effect:	not known
Mutagen effect:	not known
Reproduction-damaging effect:	not known

12. Ecological information

Mobility: Floats on water. Absorbs on soil.

Degradability / persistence:

15.4.1.1.1 Biodegradability:

Bioaccumulative potential:

Ecotoxicity: Not available.

Aquatic

organisms:

Soil organisms:

Plants:

Biological oxygen demand:

Chemical oxygen demand:

Heavy metal content: None.

PCT, PCB and other chlorinated hydrocarbons: None.
Environmental effects: Spills may form a film on water surfaces causing impaired oxygen transfer.

13. Disposal considerations

Product disposal:

Wastes of the product or used oil should be treated as hazardous waste.

EWC cod: 13 01 10* or 13 02 05*

Mineral-based non-chlorinated hydraulic oils. or

Mineral-based non-chlorinated engine, gear and lubricating oils.

Disposal must be in compliance with national and local regulations.

Packaging disposal:

Containers with product residue should also be treated as hazardous waste according to national and local disposal regulations.

EWC cod: 15 01 10*

Packaging containing residues of or contaminated by dangerous substances.

Disposal must be in compliance with national and local regulations.

Wastewater:

Quality of wastewater emitted to natural water must comply with national and local regulations.

Care should be taken in any case to ensure compliance with EC, national and local regulations. It is the responsibility of the user to know all relevant national and local regulations.

14. Transport information

Land transport:

Road/ Railway

ADR/RID:

Not classified.

Waterways:

Inland waterways/ Sea transport

ADN/IMDG:

Not classified.

Air transport: ICAO / IATA:

Not classified.

15. Regulatory information

Hazard symbol according to EU directives (67/548/EEC, 2001/59/EC, 2004/73/EC and 88/379/EEC, 1999/45/EC, 2001/60/EC) and to Hungarian regulation [44/2000. (XII. 27.) EüM rendelet (existing version)] for hazardous substances and hazardous preparations:

**Not
required.**

Hazardous component(s): -

The packaging must bear the -
inscription:

R-phrases: Not required.

S-phrases: S 60: This material and its container must be disposed of as hazardous waste.

S 61: Avoid release to the environment. Refer to special instructions/Safety data sheets.

16. Other information

Recommended application / restrictions:

See product sheets.

Information given is based on our best knowledge and is intended to describe the product for the purposes of safety of transporting and handling only. It should not be therefore construed as guaranteeing any specific property of the product.

This safety data sheet has been made according to 88/379/EEC, 91/155/EEC, 93/112/EEC and 2001/58/EC directives.

Source of data presented in this material safety data sheet:

Test results of this product

Material safety data sheets of product's components

Hungarian and EU lists of dangerous substances

Relevant Hungarian regulation and EU directives

CONCAWE database

15.4.1.1.1.1

15.4. The full text of each relevant R phrase in Section 2.:

15.4.1.1.1.3

R 36/38: Irritating to eyes and skin.

15.4.1.1.1.4

Revision Indicators:

Section	15.4.2 <u>Subject of change</u>	15.5 <u>Date</u>	Version
1.	Modification of the name	27.02.2004	1
1.	16. For more information contact	30.11.2004	2

15.	16.1.1 <u>Regulatory information</u>		
	16.1.2 <u>Other corrections</u>		
1	16.1.2.1.1.1.1.1 <i>For more information contact</i>	16.2 <u>12.09.2006</u>	3
2	16.2.1 <u>Composition / information on ingredients</u>	16.3	
9	16.3.1 <u>Physical and chemical properties</u>	16.4	
11, 14, 15, 16	16.4.1.1.1.1.1.1 <i>Regulatory information and other corrections</i>	16.5	



Ústav aplikované mechaniky Brno, s.r.o.
Zkušební laboratoř č. 1228
ČSN EN 17025:2005
Osvědčení o akreditaci č.593/2007 - ČIA Praha
Veveří 95, 611 00 Brno
www.uam.cz

PROTOKOL O ZKOUŠCE - archivní číslo: 4288_1/08

MĚŘENÍ A VYHODNOCENÍ VIBRACÍ U NÝTOVACÍHO ZAŘÍZENÍ

1. Identifikace zkoušeného zařízení:

Nýtovací zařízení RIVETEC typ TIOS H75

2. Výrobce zařízení:

RIVETEC s.r.o., Albrechtice nad Vltavou 16, PSČ 398 16, CZ

3. Zkouška provedena dle norem:

ČSN P CEN ISO/TS 8662-11:2006 Ruční mechanizované nářadí – Měření vibrací na rukojeti

ČSN EN ISO 5349-1,2:2002 Vibrace – Měření a hodnocení expozice vibracím přenášeným na ruce –

Část1: Všeobecné požadavky, Část2: Praktický návod pro měření na pracovním místě

4. Použité měřicí zařízení:

Akcelerometr – výrobce, typ, hmotnost:..... Brüel&Kjær, typ 4384, hmotnost 11 g

Akcelerometr – výr. číslo:..... 2213203

Mechanický filtr – výrobce, typ, hmotnost:..... Brüel&Kjær, typ 0559, hmotnost 16g

Zesilovač – výrobce, typ, výr. číslo: Brüel&Kjær, Nexus typ 2692, 2247655

Záznamové zařízení – typ, dodavatel: Záznamový počítač s měř. kartou ADF 16
BMC-MESSYSYSTEMS.DEPoužitý software – název, verze, dodavatel: ... NextView, ver.4.2, BMC-MESSYSYSTEMS
FlexPro, ver. 7, WEISANG.DE

5. Výsledky zkoušky - expozice celkovým vibracím na ruce pracovníka pracujícího s RHPH 75 TC:

Naměřená průměrná souhrnná vážená hodnota zrychlení a_{hv} : **0,70 ± 0,18 m.s⁻²**Hodnota použitá pro posouzení (maximálně možná hodnota) **0,97 m.s⁻²**

6. Osvědčení o zkoušce

Nýtovací zařízení RIVETEC TIOS H75 nepřekračuje přípustný expoziční limit vibrací přenášených na ruce obsluhy po osmihodinovou pracovní směnu $a_{hv,8h}$ stanovený podle Nařízení vlády ČR č. 148/2008 o ochraně zdraví před nepříznivými účinky hluku a vibrací (podle §12 musí $A(8) < 1,4 \text{ m/s}^2$) a podle Směrnice EP a Rady č. 2002/44/ES o minimálních požadavcích na bezpečnost a ochranu zdraví před expozicí zaměstnanců rizikům spojeným s fyzikálními činiteli (vibracemi), (podle § 3 musí $A(8) < 2,5 \text{ m/s}^2$). Doba jednoho nýtování musí minimálně trvat 3 sekundy.
Nýtovací zařízení RIVETEC typ TIOS H75 výše uvedené limity splňuje.

Podrobný popis a vyhodnocení zkoušky je provedeno v technické zprávě ÚAM TZ 4288/08: „Měření a vyhodnocení vibrací u nýtovacího zařízení TIOS H75“, která je k dispozici u výrobce zkoušeného zařízení na adrese: RIVETEC s.r.o., Albrechtice nad Vltavou 16, PSČ 398 16, CZ

Ing. FLORYÁN Josef
vedoucí zkušebny

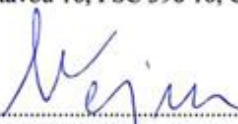

Prof. Ing. VEJVODA Stanislav, CSc.
ředitel ÚAM

V Brně dne: 17.09.2008

Název produktu:
Product Name: **TIOS H350**

Kat. číslo:
Cat. Number: **99-0128**

Určení produktu:
Specifications: hydraulický agregát určený pro pohon nýtovacího nářadí RIVETEC
hydraulic aggregate for drive of riveting tool RIVETEC

Parametry:
Characteristics: max. 35 MPa, 400 V

Výrobce

Manufacturer

RIVETEC s.r.o.
Albrechtice nad Vltavou 16
CZ-39816 Albrechtice nad Vltavou
IČ 60647761

prohlašuje, že výše uvedený výrobek odpovídá následujícím evropským normám a směrnicím a byl navržen, vyroben a posouzen ve shodě s platnou legislativou ČR:

declares that the product listed is in conformity with the essential requirements and provisions of following Council Directives and conforms to the following standards:

ČSN EN ISO 12100 Bezpečnost strojních zařízení
ČSN EN 349 Bezpečnost strojních zařízení – Nejmenší mezery k zamezení stlačených částí lidského těla
ČSN EN 953 Bezpečnost strojních zařízení – Ochranné kryty
ČSN CR 954-100 Bezpečnost strojních zařízení: části řídicích systémů
ČSN EN 983 Bezpečnost strojních zařízení – Bezpečnostní požadavky pro fluidní zařízení a jejich součásti – Pneumatika
ČSN EN 999 Bezpečnost strojních zařízení – Umístění ochranných zařízení s ohledem na rychlosti přiblížení částí lidského těla
ČSN EN 61000-6-1 ed. 2 Elektromagnetická kompatibilita – Odolnost
ČSN EN 61000-6-4 ed. 2 Elektromagnetická kompatibilita – Emise
ČSN EN 60204-1 Bezpečnost strojních zařízení – Elektrické zařízení strojů – Všeobecné požadavky
ČSN EN ISO 13850 Bezpečnost strojních zařízení – Nouzové zastavení – Zásady pro konstrukci
ČSN EN ISO 13857 Bezpečnost strojních zařízení – Bezpečné vzdálenosti k zamezení dosahu k nebezpečným místům horními a dolními končetinami
ČSN EN ISO 1037 Bezpečnost strojních zařízení – Zamezení neočekávanému spuštění
ČSN EN 614-1 Bezpečnost strojních zařízení – Ergonomické zásady navrhování – Část 1
ČSN EN 60439-1 ed. 2 Rozvaděče nn – Část 1
2006/95/ES Elektrická zařízení určená pro používání v určitých mezích napětí
2004/108/ES Elektromagnetická kompatibilita
2006/42/ES Směrnice o strojích a zařízeních
Zákon č. 22/1997 Sb. o technických požadavcích
Zákon č. 71/2000 Sb. (změna zákona č. 22/1997 Sb.)
Zákon č. 205/2002 Sb. (změna zákona č. 22/1997 Sb.)
Zákon č. 226/2003 Sb. (změna zákona č. 22/1997 Sb.)
Zákon č. 102/2001 Sb. o obecné bezpečnosti výrobků
Zákon č. 227/2003 Sb. (změna zákona č. 102/2001 Sb.)
Nařízení vlády č. 18/2003 Sb. o požadavcích na výrobky z hlediska jejich elektrické kompatibility
Nařízení vlády č. 204/2003 Sb. o technických požadavcích na strojní zařízení

Místo a datum:
Place and date:

Albrechtice nad Vltavou
27.11.2008

Jméno, funkce a podpis autorizované osoby:
Name, Title and Signature of Authorized Person:

Ing. Antonín Solfronk
Managing Director



Název produktu:
Product Name: **TIOS H40**

Kat. číslo:
Cat. Number: **99-0139**

Určení produktu:
Specifications: hydraulické nýtovací nářadí pro usazování nýtů
hydraulic riveting tool for installing rivets

Parametry:
Characteristics: tažná síla / setting power: 30,7 kN / 35 MPa; 39,3 kN / 45 MPa

Výrobce

Manufacturer

RIVETEC s.r.o.
Albrechtice nad Vltavou 16
CZ-39816 Albrechtice nad Vltavou
IČ 60647761

prohlašuje, že výše uvedený výrobek odpovídá následujícím evropským normám a směrnicím a byl navržen, vyroben a posouzen ve shodě s platnou legislativou ČR:

declares that the product listed is in conformity with the essential requirements and provisions of following Council Directives and conforms to the following standards:

ČSN EN ISO 12100 Bezpečnost strojních zařízení
ČSN EN 349 Bezpečnost strojních zařízení – Nejmenší mezery k zamezení stlačených částí lidského těla
ČSN EN 953 Bezpečnost strojních zařízení – Ochranné kryty
ČSN CR 954-100 Bezpečnost strojních zařízení: části řídicích systémů
ČSN EN 983 Bezpečnost strojních zařízení – Bezpečnostní požadavky pro fluidní zařízení a jejich součásti – Pneumatika
ČSN EN 999 Bezpečnost strojních zařízení – Umístění ochranných zařízení s ohledem na rychlosti přiblížení částí lidského těla
ČSN EN 61000-6-1 ed. 2 Elektromagnetická kompatibilita – Odolnost
ČSN EN 61000-6-4 ed. 2 Elektromagnetická kompatibilita – Emise
ČSN EN 60204-1 Bezpečnost strojních zařízení – Elektrické zařízení strojů – Všeobecné požadavky
ČSN EN ISO 13850 Bezpečnost strojních zařízení – Nouzové zastavení – Zásady pro konstrukci
ČSN EN ISO 13857 Bezpečnost strojních zařízení – Bezpečné vzdálenosti k zamezení dosahu k nebezpečným místům horními a dolními končetinami
ČSN EN ISO 1037 Bezpečnost strojních zařízení – Zamezení neočekávanému spuštění
ČSN EN 614-1 Bezpečnost strojních zařízení – Ergonomické zásady navrhování – Část 1
ČSN EN 60439-1 ed. 2 Rozvaděče nn – Část 1
2006/95/ES Elektrická zařízení určená pro používání v určitých mezích napětí
2004/108/ES Elektromagnetická kompatibilita
2006/42/ES Směrnice o strojích a zařízeních

Zákon č. 22/1997 Sb. o technických požadavcích
Zákon č. 71/2000 Sb. (změna zákona č. 22/1997 Sb.)
Zákon č. 205/2002 Sb. (změna zákona č. 22/1997 Sb.)
Zákon č. 226/2003 Sb. (změna zákona č. 22/1997 Sb.)
Zákon č. 102/2001 Sb. o obecné bezpečnosti výrobků
Zákon č. 227/2003 Sb. (změna zákona č. 102/2001 Sb.)
Nařízení vlády č. 18/2003 Sb. o požadavcích na výrobky z hlediska jejich elektrické kompatibility
Nařízení vlády č. 204/2003 Sb. o technických požadavcích na strojní zařízení

Místo a datum: Albrechtice nad Vltavou
Place and date: 27.11.2008

Jméno, funkce a podpis autorizované osoby:
Name, Title and Signature of Authorized Person: Ing. Antonín Solfronk
Managing Director

